

EFFECTIVE FEB 2018 UPDATED JULY 2018



Reception park.

price list

reception park price list revisions

DATE	PAGE	MODIFICATION	DESCRIPTION
2.1.18	All	Added finish	Added WBW Henna Walnut finish
7.11.18	/	Edited Dimn.	Edited dimn. on TC224, TC464, TC467, TC471, TC472

TABLE OF CONTENTS

Product index 2

General Information 3

Limited Lifetime Warranty 4

Damages | Returns | Repairs 5

Ordering Information 6

GSA Customer Information 7

Freight..... 8

Features & Advantages 9

Finishes | Specifications..... 10

Edges | Pulls 11

Grommets | Grommet Reference 12

Ganging | Height Reference 13

Modesty Reference | Grain Direction..... 14

Drawer Dimensions | Filing Reference 15

Desk Shells 16

Corner Shells..... 17

Reception Workstation Returns 18

Bridges 20

Reception Workstation Credenzas 21

Pedestals 24

Counters..... 25

Options 31

Power and Data..... 38

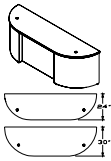

PAGE 16
DESK SHELL

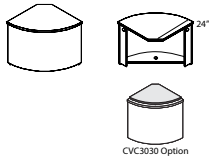

PAGE 17
CORNER SHELLS

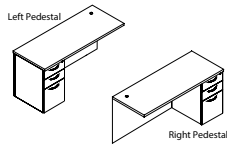

PAGE 18
RECEPTION WORKSTATION
RETURNS 24" D

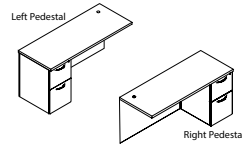

PAGE 19
RECEPTION WORKSTATION
RETURNS 24" D

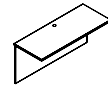

PAGE 20
RECEPTION "U" WORKSTATION
BRIDGES

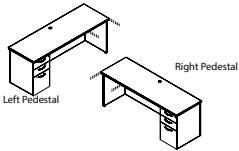

PAGE 21
RECEPTION WORKSTATION
CREDENZA

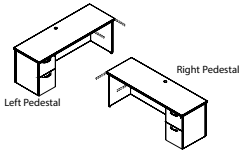

PAGE 22
RECEPTION WORKSTATION
CREDENZA

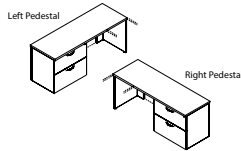

PAGE 23
RECEPTION WORKSTATION
CREDENZA

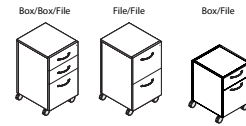

PAGE 24
PEDESTALS

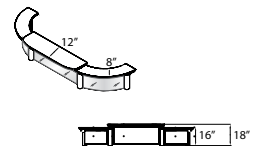

PAGE 25
COUNTERS

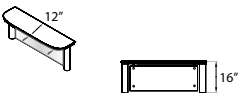

PAGE 26
COUNTERS

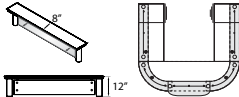

PAGE 27
COUNTERS

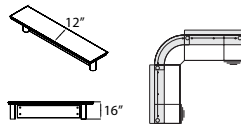

PAGE 28
COUNTERS



PAGE 29
COUNTERS



PAGE 30
COUNTERS



All DARRAN products are proudly manufactured in the U.S.A.

BUILT TO ORDER

Manufactured per order the way you want it, including modifications.

FULLY ASSEMBLED

Unless otherwise noted, all products are fully assembled and ready to use, including add-on options.

PERFORMANCE TESTED

All products are tested to ensure performance exceeds BIFMA / ANSI standards.



GREEN CERTIFIED

DARRAN has been committed to improving indoor air quality of office buildings since 1996. Since then, finish technology has allowed our commitment to continue with products that are air quality Certified Green.

DARRAN is proud to announce that all in veneer, laminate, and guest seating are MAS Certified Green for complying with the ANSI/BIFMA X 7.1 standard / LEED 4.5 Standard for low –VOC emitting Furniture.

MAS is an independent emission testing laboratory that is ISO 17025 compliant using ASTM, ANSI and CEN methods. MAS is a true 3rd party certification through NSF International to BIFMA standards and California’s ARB formaldehyde standard. Certification of compliance under the Low – VOC emitting Furniture testing, qualifies products for LEED 4.5 credits.



FINISH TECHNOLOGY

DARRAN has continued its partnership with AkzoNobel Chemicals (www.akzonobel.com) to develop a new finish technology further improving indoor air quality with a coating that meets today’s environmental standards and supports LEED buildings.

ENVI-CT (Environmental Coatings Technology) utilizes advanced European finish technology to deliver a high-end furniture coating with superior performance in appearance and durability, allowing DARRAN to deliver more sustainable products to our customers.

ENVI-CT Advantages:

- › ENVI-CT is a re-engineered high performance Coatings Top Coat
- › Exceptional hardness and clarity
- › Highly resistant to solvents and chemicals
- › Plasticizer Migration resistant
- › Excellent UV inhibitors for maximum color resistance
- › Exceeds current and proposed future Federal and State air quality requirements
- › Field Repairable
- › Dynamic chamber emissions tested and certified compliant to ANSI/BIFMA X 7.1 Standard / LEED 4.5 Standard for low – VOC emitting furniture.

ADVANTAGES

DARRAN collaborated with the world’s leader in finishing materials, to formulate an additive that will inhibit the growth of mold, mildew, fungus and bacteria on wood surfaces. This additive infuses Silver Ions into DARRAN’s ENVI-CT (Environmental Coatings Finish Technology), creating a protective surface for the life of the furniture. The best part - is standard on all DARRAN Casegoods for no additional fee.

LIMITED LIFETIME WARRANTY

DARRAN Furniture Industries, Inc. ("DARRAN") warrants that each piece of furniture manufactured in its North Carolina Facilities will be free from defects in material and workmanship for as long as the original purchaser owns and uses the product. Subject to the limitations and exclusions herein, DARRAN, at its discretion and as the sole remedy under the DARRAN Limited Lifetime Warranty, will replace or repair a defective product or components with comparable product or components free of charge. This warranty is made only to the original purchaser from an authorized DARRAN dealer, for as long as that original purchaser owns and uses the product.

LIMITATIONS: USE / CARE

- › Warranty is limited to normal single shift use.
- › Warranty is limited to generally accepted care and maintenance of natural wood products and environments.
- › Natural wood surfaces are subject to denting, scratching, and gauging if not properly used and cared for. Warranty is subject to use and care in accordance with the use and care instructions provided in the Product Care section of this site (including, but not limited to, the care and maintenance guide downloads linked thereon), available at www.darran.com/product-care, which are incorporated herein by reference.

LIMITATIONS: MATERIALS / COMPONENTS

- › Laminates, Veneers / Finishes - 10 Years
- › Electrical lamps, Ballasts, Transformers - 3 Years
- › Fabrics, Pneumatic lifts, Foam - 5 Years
- › Custom products built to customers specifications - 3 Years

WARRANTY EXCLUSIONS

Damage identified as carrier or installer related.

- › Normal wear and tear of wood products during course of ownership.
- › Color, grain, or texture of natural wood materials, laminates, and other covering materials.
- › Damages or failures resulting from misuse, abuse, negligence, improper care, modifications, or relocation.
- › Non Commercial use or locations.
- › So-called "ghost" indentions and similar damage caused by the failure to use appropriate desk or writing pads.

All Warranty Claims are subject to DARRAN-approved inspections. Disputes may involve independent third-party evaluation

QUALITY ASSURANCE

DARRAN manufactures in accordance with the standards set by Architectural Woodwork Institute (AWI) for Quality Standards.

Every unit produced at DARRAN is completely inspected by an independent quality control team located within each plant whose emphasis is on assembly, finish, and final inspections with empowerment to stop any unit not meeting DARRAN's high quality standards.

LIGHT AND NATURAL FINISHES

The beauty of veneer and all wood products comes from the variations created by nature including color, grain, and texture.

These variations are not considered defects and DARRAN's Limited Lifetime Warranty does not cover color, grain and texture variations associated with natural wood and grain seen in any finish color. DARRAN sets standards for veneer selections; however, variations, especially apparent in light/natural finishes, will occur from one piece to another even if they are finished at the same time.

Finishes such as Clear Maple, Light/Gunstock Walnut, and Clear/Caramel Cherry will display more natural characteristics due to their light stain. Grain, pattern and color from unit to unit are not guaranteed or warranted and products will not be replaced due to these variations. Exposure to light and age will cause darkening of natural wood products; therefore DARRAN cannot guarantee or warrant finish match of new products being placed with existing products in the field.

GLASS

Use of glass overlays on surfaces will void DARRAN's Limited Lifetime Warranty, unless the overlay is installed and maintained in strict accordance with DARRAN's instructions. If an overlay is to be used, please contact DARRAN for installation and maintenance instructions.

GENERAL

Performance questions will be tested to generally accepted practices and AWI guidelines and standards for wood veneer furniture. To obtain performance of the Limited Lifetime Warranty, the purchaser should contact in writing the authorized DARRAN representatives or current dealer who sold the product to the purchaser or mail the warranty claim to:

Warranty Department
DARRAN Furniture Industries, Inc.
P.O. Box 7614
High Point, NC 27264
Telephone: 336-861-2400 Toll Free: 800-334-7891
email: warranty@darran.com

EXCEPT FOR THE LIMITED LIFETIME WARRANTY EXPRESSLY DESCRIBED HEREIN, DARRAN MAKES NO OTHER REPRESENTATION OR WARRANTY OF ANY KIND, EXPRESS OR IMPLIED. DARRAN MAKES NO WARRANTY OF MERCHANTABILITY OR FITNESS FOR A PARTICULAR PURPOSE, AND DARRAN WILL NOT UNDER ANY CIRCUMSTANCES BE LIABLE FOR ANY INCIDENTAL OR CONSEQUENTIAL DAMAGES, OR ANY INDIRECT OR SPECIAL DAMAGES.

THE WARRANTY AS STATED ABOVE, SUPERSEDES ALL PREVIOUS WARRANTIES

NO HASSLE FREIGHT DAMAGED MERCHANDISE

DARRAN products are packed in specially designed cartons and padding that protects all edges and corners from damage. This is proven by an industry low damage rate of .0030% per total pieces shipped.

For qualified freight damage claims DARRAN will take responsibility for the claim and remedy processes including assuming total cost coverage from claim settlements.

(Some items may not qualify. Contact Factory for specific details.)

QUALIFIED CLAIM CONDITIONS**VISIBLE CARTON DAMAGE**

1. Take digital pictures of the damaged carton and damaged furniture if visible damage is found upon delivery at the dock
2. Open all cartons with puncture or crushed corner damage.
3. Note any damage to the goods on the Carrier's freight bill as number of pieces damaged.

CONCEALED DAMAGE

1. Take digital pictures of the furniture as it sits partially unpacked. Also, photograph external and internal carton materials that correspond with the damaged area on the product.
2. Carton and damaged unit(s) must be located at the location matching the original delivery address for Carrier inspection.
3. Digital pictures must be provided of the damaged furniture and carton materials

For qualified claims per above contact DARRAN Customer Service Department at 1-800-334-7891 or complete DARRAN's online warranty report form within the 15 day limit. www.darran.com/warrantyreport

NON-QUALIFIED CLAIM CONDITIONS

1. Deliveries made to non-dock locations
2. Claims made after furniture is installed and/or removed from original delivery location
3. Carton and padding has been discarded
4. Carrier used was not DARRAN approved
5. Inspection reveals questionable damages

REPLACEMENT ORDERS

Replacement orders entered without replacement tagging or factory authorization is considered a new order without dispute, therefore full payment is expected and will be collected.

RETURN SHIPMENTS

DARRAN will not accept return of merchandise without a signed RA (return authorization) form.

DARRAN will specify the carrier to be used. Return bills of lading must be marked "Class 125" freight rate and a copy of the RA should be used as a packing list. All returns must be received by DARRAN within 30 days of the RA date or the products will be considered accepted by the customer.

All products being returned must be properly packed and protected to avoid freight damage. Whenever possible, use the original cartons in which the merchandise was shipped. Freight

damage, signs of usage, missing parts, etc., will result in an adjustment of any credit to be issued.

DARRAN will issue RA's for the following reasons:

1. Manufacturing defect (inspection required)
2. Order processing error by DARRAN
3. Shipping error
4. Mismatched carton / merchandise

SPECIFICATION CHANGES

We reserve the right to change without notice any dimension, style, or specification of any model in the DARRAN line. Dimensions shown in the price list are nominal. It is the buyer's responsibility to read specification carefully when matching existing goods is desired.

MANUFACTURING DEFECTS

Claims of manufacturing defects will not be entertained without prior consultation with DARRAN's warranty department. Unauthorized deduction in payment of invoices will not be allowed without prior factory approval. Unapproved deductions are subject to factor's late payment charges.

DAMAGE CLAIMS

Claims of manufacturing damage or freight damage reported as nicks, dents, scratches, etc. after installation of furniture will not be covered under warranty or freight claim.

ATTENTION: Damage claims involving glass or stone components must be inspected and damage noted on delivering freight bill to qualify for replacement.

REPAIR CHARGES

Factory authorization must be secured from DARRAN's warranty department prior to incurring repair charges. Warranty will utilize DARRAN's National Repair Service through the Furniture Medic Franchise (www.furnituremedic.com).

Repair charge authorizations are based on:

- › Set travel rate
- › Average regional job rate
- › Factory set maximum repair time
- › Falsely reported defect claims are subject to local service charges being charged to dealer/distributor.

FINISH MAINTENANCE

Wood office furniture and wood finishes can retain their natural beauty for life if proper care is taken and a stable environment is provided. Fluctuations in humidity and temperature cause panels and solid wood components to expand and contract and may lead to panel warpage and finish "checking" or cracking. Prolonged exposure of furniture to dry heat during winter months should be avoided. Careful examination of interior wood trim may indicate a damaging dry environment. If open joints, splits and cracks are appearing in trimwork consult with a HVAC professional for appropriate remedy.

DARRAN finishes are field repairable should damage occur. Professional furniture repair services are recommended. Regular cleaning with a non-silicone polish is recommended.

ORDERING

All orders should be emailed, mailed or transmitted by fax to:

DARRAN Furniture Industries, Inc.
P.O. Box 7614
High Point, NC 27264
email: orders@darran.com
Fax: 336-861-6485

DARRAN will only accept orders from authorized Dealers. All orders must be accurate and detailed. All Quick Ship orders must contain Quick Ship product ONLY. Orders should be separated and submitted according to lead time. Orders must contain Quick Ship code "QS" or have designated Quick Ship lead time to ensure correct order entry. Orders that contain multiple lead time products will be entered as one order and scheduled with the most extended lead time.

CREDIT APPROVAL

All orders are subject to credit approval for open account. All new accounts must be approved by a local DARRAN Sales Representative and should submit current financial information and trade references to:

DARRAN Furniture Industries, Inc. ATTN: Credit Department
P.O. Box 7614
High Point, NC 27264
Telephone: 336-861-2400 Toll Free: 800-334-7891
Fax: 336-861-2512

Orders submitted without accounts pre-approval or credit approval are subject to acceptance with lead times scheduled only after approval dates.

LEAD TIME SCHEDULE

DARRAN cannot assign a firm lead time until Credit approval and order accuracy are complete. Extended lead times due to credit or information delays are the responsibility of the Buyer.

ORDER DELAY / HOLD

Due to the committed manufacturing cost on Quick Ship processes, DARRAN cannot delay or hold orders, either in process or after completion.

CANCELLATION AND ORDER CHANGES - FEES

Acknowledged orders are considered firm orders and therefore not subject to cancellation or change. However, in the event we are able to stop an order prior to manufacturing process, we will consider cancellation or changes with a reprocessing fee of \$40.00 Net. Exceptions: Quickship orders cannot be changed or canceled after the 3rd business date after acknowledgment. Qualified changes/cancellations will be assessed a \$40.00 Net processing fee.

Changes or cancellation of order with special options or custom quoted items are also subject to additional material and vendor fee costs, plus a DARRAN special/custom reprocessing fee of \$100 NET.

ORDER MOVEUPS

Should an original scheduled ship date need to be improved, the Factory must be contacted 15 business days prior to the desired ship date. Move ups are subject to schedule availability.

ORDER ACKNOWLEDGMENT

Upon credit approval your order will be acknowledged and identified by an order number. When making reference to your order, please use this order number. Your acknowledgment is a detailed description of our interpretation of your order, pricing, shipping information, and estimated delivery date.

If you have not received an Acknowledgment within 10 Days of order issue, contact Customer Service immediately. All Quick Ship order acknowledgments will be faxed or emailed upon request to speed processing. Please read your acknowledgment carefully for correctness and notify DARRAN immediately of any discrepancies. Failure to notify relieves DARRAN from error liability.

Order acknowledgment is the final agreement between DARRAN and the customer superseding all previous communications regarding the order. DARRAN will not be responsible for errors made on orders placed by phone without written confirmation.

SELLING INFORMATION

Possession of this price list does not in itself constitute the right to sell DARRAN products. DARRAN products are sold and distributed through authorized dealerships. Contact factory for a listing of local representatives and dealerships.

INVOICE TERMS

Standard terms are NET 30 days. Finance charges of 1-1/2% will be added to delinquent accounts after 45 Days and for each 30 Days thereafter until paid.

Complaints involving newly received merchandise must be reported within 10 days from receipt to qualify for full invoice remittance suspension or term extension. Otherwise only items in dispute can be suspended from payment of invoice within terms.

WAREHOUSE/STORAGE

DARRAN will determine order warehousing approvals on a case by case basis. Orders that can be accommodated will be limited to a max of 30 days storage and must be invoiced at time of storage. Orders that exceed factory storage capacity will be transferred to local storage facilities subject to current storage rates and handling-transit charges. Storage charges must be paid prior to order release to shipping.

**EXECUTIVE OFFICE & CONFERENCE ROOM
FURNITURE**

November 3, 2015 through November 2, 2020

FSC Group 71

GSA CONTRACT NUMBER: GS-27F-001DA

Business Classification:

WBENC Certified Woman-Owned Small Business

DARRAN FURNITURE INDUSTRIES

2402 SHORE DRIVE

HIGH POINT, NC 27263

336.861.2400 FAX 336.861.6485

Business Classification:

Woman-Owned Small Business

On-line access to contract ordering information, terms and conditions, up-to-date pricing, and the option to create an electronic delivery order are available through GSA Advantage!, a menu driven database system. The INTERNET address for GSA Advantage is <http://www.fss.gsa.gov>

For more information on ordering from Federal Supply Schedules click on the FSS Schedules button at <http://www.fss.gsa.gov>

1a. Special Item Number

711-8: Executive Office Furniture

711-9: Executive Conference Room Furniture

711-11: Tables and Accessories

711-16: Upholstered Seating

711-18: Multi-purpose Seating

2. Maximum Order Limitations:

711-8 \$500,000

711-9 \$500,000

711-11 \$500,000

711-16 \$300,000

711-18 \$200,000

3. Minimum Order: \$100

4. Geographic Coverage: 48 Contiguous States and the District of Columbia

5. Point of Production: High Point, North Carolina (Randolph County)

6. Discount: Prices shown herein are List (Discount is 56.9% Off List)

7. Quantity Discounts:

• \$467,837 List to \$1,000,000 List = 59.70%

• \$1,000,001 List to \$1,315,789 List = 61.70%

8. Payment Terms: ½% - Net 15 Days, Net 30 Days

8a. Terms and Conditions of Government Credit Card Acceptance:

a. No discount allowed for payment by Government Purchase Card

b. Provide commercial credit card number

c. Provide commercial credit card expiration date

d. Provide individual's name as it appears on

credit card

e. Provide telephone number of individual to whom credit is issued

9a. Government Purchase Cards are accepted below the Micro Purchase Threshold.

9b. Government Purchase Cards are accepted above the Micro Purchase Threshold.

10. Foreign Terms: None

11a. Time of Delivery: Regular Product: 60 - 90 days after receipt of order

Quick Ship Program: Contact DARRAN

11b. Quick Ship Program: Items available for expedited delivery are included in main Price Lists.

11c. Overnight and 2-day delivery: N/A

11d. Urgent Requirements: Will be considered on an individual basis. Contact DARRAN for details.

12. FOB Point: All destinations are limited to Commercial docks only. Carriers may refuse non-dock deliveries.

12a. Freight Prices:

a. All prices shown are suggested list prices with freight included where indicated.

b. Freight allows delivery to one qualified destination.

c. Within the Continental USA, all orders above \$1,500 net are shipped FOB factory, freight prepaid and allowed. All orders less than \$1,500 net will be subject to a \$100 net freight charge.

13. Ordering Address:

DARRAN Furniture Industries

P.O. Box 7614

High Point, NC 27264

Ph: 800.334.7891

Fax: 336.861.6485

13a. Payment Address:

Rosenthal & Rosenthal Southeast

P.O. Box 733909

Dallas, TX 75373-3909

14. Warranty Provision: Limited Lifetime (Contact DARRAN for details)

15. Export Packing Charges: Quoted on request

13. Terms and Conditions: Order Cancellation / Changes.

Restocking/Returns: No merchandise may be returned without a return authorization and shipping instructions. No credit or allowance will be given for repairs to defective materials unless DARRAN has given authority to make such repairs. A restocking charge of 25% will apply.

Cancellation: No cost prior to production. After

gsa customer information

production has begun, only actual cost incurred will be billed to the Government that cannot be recovered through resale in 6 months

14. Terms and Condition of Rental, Maintenance and Repair: Consult the Factory.

15. Terms and Conditions of Installation: Installation by a Third party to be quoted on a per job basis. The ordering must specify what ranges of installation services are required.

16. Terms and Conditions of Repair Parts: Contact DARRAN for details.

17. List of Service and distribution points: Contact DARRAN for details..

18. Preventative Maintenance: Information enclosed with product.

19. List of Participating Dealers: Contact DARRAN for details.

23. Environmental Attributes: DARRAN is compliant with EPA standards. All plywood core material is CARB 2 compliant and contains recycled content. All DARRAN Casegood Products are BIFMA Level 2 Certified. DARRAN is FSC CoC Certified and our products are MAS Certified for Indoor Air Quality.

23a. Recyclable and Recycled Content Packaging:

The corrugated packaging that is supplied to DARRAN, meets the federal mandate that requires the paperboard to be composed of 30%-50% recycled paper, and in some cases the recycled content is close to 100%.

23b. Chemical Emission: DARRAN finishes its products in an ENVI-CT Finish. (Environmental Coatings Technology). DARRAN's seating is finished with a low VOC Conversion Varnish and the casegoods are finished with a formaldehyde free, low VOC Urethane finish. These ENVI-CT finishes allow DARRAN's products to be MAS Certified Green under the ANSI BIFMA X7.1 Standard. Products assist with LEED 4.5 Credit.

23c. Vapor Emissions: DARRAN's ENVI-CT finishes use the latest environmental coatings technology to provide lasting durability and exceptional clarity. The ENVI-CT finishes allows DARRAN casegoods to be MAS Certified Green meeting LEED Credit 4.5.

24a. Duns Number: 08-363-5318

24b. Cage Code: 0Y-6B6

24c. Federal ID Number: 56-117-1971

24d. NAICS Code: 337211

25. SAM Network: DARRAN is registered

SHIPPING SCHEDULE

DARRAN will make every effort to match shipping requests that are clearly noted on orders. However, the company accepts no liability for failure of delivery and/or delay if the occurrence is outside the control of DARRAN. To ensure specific time arrival, we recommend arranging single stop, designated load carriers. Less than trailer load (LTL) shipments cannot be coordinated for a guaranteed delivery time.

PRICES

- › All prices shown are suggested list prices with freight included where indicated.
- › Freight allows delivery to one qualified destination.
- › Within the Continental USA, all orders above \$1,500 net are shipped FOB factory, freight prepaid and allowed. All orders less than \$1,500 net will be subject to a \$100 net freight charge.
- › If shipment unloading takes longer than the specified 3 hours, a charge of \$100 per hour will be billed.

CALL BEFORE DELIVERY REQUEST

DARRAN will arrange for carriers to call before delivery when requested.

Important Non-Qualified Destinations DARRAN Prepaid Freight Pricing does not include delivery to:

- › Residential Areas
- › Restricted Commercial Areas
- › No Dock Locations
- › Inside delivery/setup service

Orders received and installed without professional Furniture Installers voids all Warranty Coverage.

CARRIER SELECTION

DARRAN selects and uses only carriers specialized in furniture transportation. Customer requested carriers can be authorized using Freight Excluded pricing with invoice add-on.

EXPRESS CARRIERS

DARRAN assumes no responsibility for charges incurred caused by delayed or late deliveries. If a guaranteed delivery time is needed please call DARRAN Customer Service at 1.800.334.7891 for a quote as additional charges will apply. Weekend or after-hours deliveries are subject to additional charges.

FEATURES & ADVANTAGES

VENEER AND HPL TOPS

Veneer tops and high-pressure laminate tops feature a 45-pound density substrate with balanced 3-ply construction. Tops are 1" thick and connected to the frame with a top horn assembly. DARRAN only uses HPVA A Grade Flat Cut Cherry, Maple, and Walnut Veneers. Cherry and Walnut veneers are book-matched. Oak, Maple, and Ash Veneers are slip-matched. Veneer tops feature a 3mm external solid hardwood band, HPL tops feature a 2mm flat PVC band or a laminate self-edge.

CHASSIS & PEDESTAL CONSTRUCTION

All pedestals and chassis are constructed with 3/4" thick balanced 3-ply panels. Panels are securely fastened together using rails that are bored and doweled, glued, metal reinforcement brackets and wood cleat construction. Thick end panels are pre-bored to accept a tee nut for the adjustable glide and are reinforced with pvc banding to prevent glide tear out. Glue blocks are used where 3/4" thick panels are joined, bored for tee nut to accept adjustable glide.

ADJUSTABLE GLIDES

Glides provide 1" of vertical leveling adjustment. Glide bottom is durable metal.

DRAWERS

All drawers are constructed of four sides and a bottom, which are attached to a drawer front with screws for easy removal. Drawer fronts feature vertically matched veneer within each pedestal. Pencil trays are standard in all box drawers. Jamestown, Prado, Rift, and Spaces feature maple veneer 1/2" thick material for drawer sides, fronts and backs with a UV finish for maximum durability. Drawer bottoms are 7/32" thick 3-ply maple veneer. Drawer boxes are assembled at each corner with dowel joinery for maximum drawer strength. Capitol Park, Central Park, NSsq, Reception Park, and Richmond Park feature drawers that are 1/2" thick wood grained wrapped 5 sided miter-folded construction with 1/8" thick hardboard bottoms.

SUSPENSIONS

All caseloads utilize cold rolled steel zinc plated high-grade drawer suspensions. All suspensions are warranted for the lifetime of the product. Box and File drawers are full extension, featuring steel ball bearings for a smoother quieter range of motion with soft close operation and are rated 100lbs. Lateral file drawers are a progressive action full extension suspension with the soft close operation and is rated at 150lbs. Lateral files include anti tip mechanism that will allow only one drawer at a time to be opened.

HINGES

Units with doors include 95 degree swing hinges.

FILING

Capitol Park, Central Park, NSsq, Reception Park, and Richmond Park feature a highly durable black plastic extrusion that is securely fastened into a route on top of the drawer. Desk drawers are provided with a cross bar that allows for adjustability for letter or legal filing side to side, letter width

filing front to back without the use of a cross bar. Credenza and Return filing is letter width front to back and legal width side to side without the use of a cross bar, letter width side to side with the use of a cross bar. Lateral files feature legal with filing side to side and two rows of letter width front to back with the use of cross bars.

Jamestown, Prado, Rift, and Spaces feature metal file frames around the perimeter of the drawers with cross bars. Desk drawers are provided with a cross bar that allows for adjustability for letter or legal filing side to side, letter width filing front to back without the use of a cross bar. Legal width drawers are specified on desks 72" and larger, and filing is legal front to back or two rows letter side to side. Credenza and Return filing is letter width front to back and legal width side to side without the use of a cross bar, letter width side to side with the use of a cross bar. Lateral files feature legal with filing side to side and two rows of letter width front to back with the use of cross bars.

LOCKS

Silver, black or bronze face locks are standard on all desks, credenzas, returns, and modular pedestals and match the color of the pull selection. Locks are optional on door storage, overhead storage, towers with doors and all door units. Each drawer pedestal is independently locked. Lock plugs are factory or field installed.

KEYING

Keying is available either factory or field installed. Factory installed keying offers two options: random or designated. When the random keying option is selected an arbitrary key number will be assigned to the unit. When the designated keying option is selected a key number must be specified between 101 and 110. Higher numbers may be specified if noted on the purchase order and may be factory or field installed. Black and silver face lock have silver keys and bronze face locks have brass keys.

WIRE MANAGEMENT

Wire management capabilities include standard and optional worksurface grommets. Specify W-1 under surface wire channels for organization and management of all communication wires and cords. Horizontal J-Channel wire management (Sku: W-1) is sold separately to conceal wire under worksurfaces.

GROMMETS

Metal grommets are provided to match the drawer pull selection. Grommet is available in black, silver, white or antique brass. Must specify standard or non-standard location. Black plastic grommets are available as an option for vertical applications.

POWERPORTS

A large selection of powerports are available and handle power, data, docking stations and communication. See options section for selection.

FINISHES

"W" VENEER	"G" LAMINATE HPL TOPS	"M" THERMALLY FUSED LAMINATE
WAC Amber Cherry	GAC Amber Cherry	N/A
WRC Caramel Cherry	N/A	N/A
WIC Crimson Cherry	GIC Crimson Cherry	N/A
WEC Ebony on Cherry	N/A	N/A
WHC Honey Cherry	GHC Honey Cherry	N/A
WOC Koko Cherry	GOC Koko Cherry	N/A
WSC Scotch Cherry	N/A	N/A
WCM Clear Maple	GCM Clear Maple	N/A
WWM Wheat Maple	GWM Wheat Maple	N/A
WEW Executive Walnut	GEW Executive Walnut	N/A
WGW Gunstock Walnut	N/A	N/A
WBW Henna Walnut	N/A	N/A
WJW Judicial Walnut	N/A	N/A
WNW Natural Walnut	GNW Natural Walnut	N/A

Send 3x3 or larger finish chip for color match. Custom finish upcharge is 3% or \$250 Net (whichever is greater).

FINISH

ENVI-CT Green Certified European Technology Coatings Finish.

VENEER AND HPL TOPS

Veneer tops and high-pressure laminate tops feature a 45-pound density substrate with balanced 3-ply construction. Tops are 1" thick and connected to the frame with a top horn assembly. DARRAN only uses HPVA A Grade Flat Cut Cherry, Maple, and Walnut Veneers. Cherry and Walnut veneers are book-matched. Oak, Maple, and Ash Veneers are slip-matched. Veneer tops feature a 3mm external solid hardwood band, HPL tops features a 2mm flat PVC band or a laminate self-edge.

CHASSIS

¾" thick core, Medium Density Fiberboard (MDF) rated EPP/SCS/CARB-II material with 3 ply balanced construction. Pedestal and cabinets feature dowel construction reinforced with steel bracket plates, wood cleats, screws and glue. Exposed interiors feature finished veneer of same species as exterior faces. Panel molding standard on approach and end panels of all worksurface height units.

NOTE: All units are standard with 1" adjustable glides that allow for leveling of units.

DRAWER FRONTS

Drawer fronts are vertically matched in balanced sets. Doors feature vertical veneer bookmatched horizontally in sets of 2 / 4 and 6 doors. All drawers and doors have traditional scallop profile edge shape. All tower fronts matched in vertical sets.

DRAWERS

Drawers feature mitre joint / dowel construction with a natural maple finish. All drawers extend 100% for full access on steel ball bearing slides with cushion in-out stops. Drawers have been tested and passed BIFMA 50,000 cycle test. File drawers feature ¼" bottoms reinforced for heavy weight capacity. All drawers are guaranteed lifetime with free replacement warranty.

OPTIONAL WOOD DRAWERS

Optional hardwood veneer plywood drawers feature banded top and bottom edges for smoothness. Drawers are dowel joint construction with a UV cured finish over maple veneers, plus a lifetime free replacement guarantee.

Optional Wood Drawer (Any Size) – Option Code P33...\$40 List Price Per Drawer

RANDOM LOCKS & KEYING (STANDARD)

Locks are standard on all storage units below the worksurface. Random lock cores are installed at the factory. Some units may be shipped with the same key number. Locks are Silver, Black or Bronze and match pull finish unless specified.

- SRK: Random Silver Random Key - n/c
- BRK: Random Black Random Key - n/c
- ZRK: Random Bronze Random Key - n/c

FIELD INSTALLED LOCKS & KEYING (OPTION)

Field installed lock option can be selected, each unit is shipped with an empty lock cylinder. A separate line item must be ordered to receive the numbered lock cores for field installation. Field installed locks are available at no additional charge. Specify Silver or Black Locks.

- SFK: Field Installed Silver Random Key - n/c
- BFK: Field Installed Black Random Key - n/c
- ZFK: Field Installed Bronze Random Key - n/c

STANDARD PROFILE

Reception Park Edge
 Hardwood Rim Band Species Same As Surface Veneer

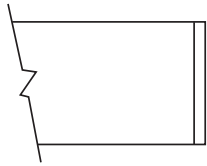

FLAT

3mm solid
 hardwood band

COUNTERTOPS

Knife Edge - Standard Edge No additional upcharge
 Flat Edge - Optional Edge - No additional upcharge

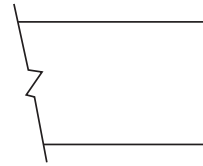

FLAT

"W" or Solid Surface

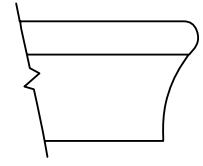

KNIFE

"W" "G"

Choice of veneer, laminate or solid surface
 countertops.

PULLS

Factory Installed

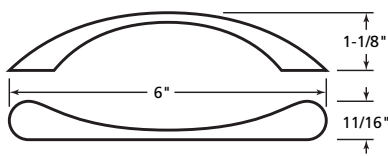

PL-105 Matte Black
 PL-106 Matte Nickel

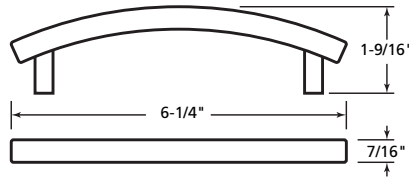

PL-112 Matte Black
 PL-113 Matte Nickel

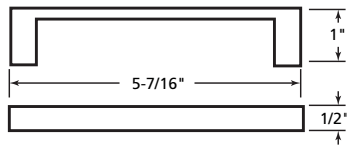

PL-115 Matte Black
 PL-116 Matte Nickel

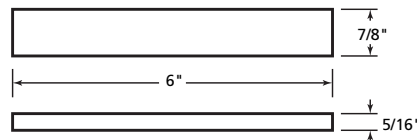

PL-210 Anodized Aluminum

OPTIONAL GROMMETS

Factory Installed

Grommets (Standard Location)

Specify Color and Left/Right/Center - \$45 ea.

- Black: TM30-R (Right), TM30-L (Left), TM30-C (Center)
- Silver: TM31-R (Right), TM31-L (Left), TM31-C (Center)
- Antique Brass: TM33-R (Right), TM33-L (Left), TM33-C (Center)

Grommets (Non-Standard Location)

Provide drawing w/ Grommet Location and Specify Color - \$90 ea.

- Black: TM30-NS
- Silver: TM31-NS
- Antique Brass: TM33-NS

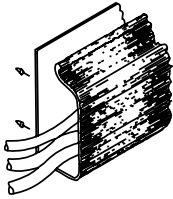

Horizontal J-Channel wire management (Sku: W-1) is sold separately to conceal wire under worksurfaces.

W1



GROMMETS (VERTICAL SURFACE)

Standard Location - \$45 ea.

- Black Plastic Vertical Surface: TM50-C (Bottom Center)

Non-Standard Location - \$90 ea.

- Black Plastic Vertical Surface: TM50-NS

STANDARD GROMMET LOCATION REFERENCE



Bridge

Center Grommet



Return (Left Pedestal Shown)

Right Pedestal - Left Grommet

Left Pedestal - Right Grommet

HEIGHT REFERENCE

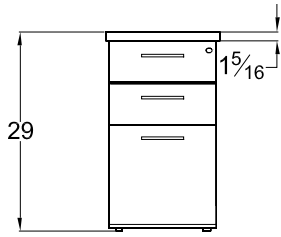

Pedestal Front Profile
Box/Box/File

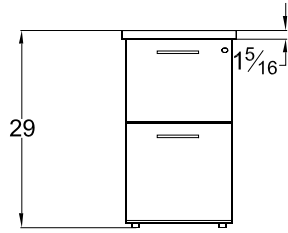

Pedestal Front Profile
File/File

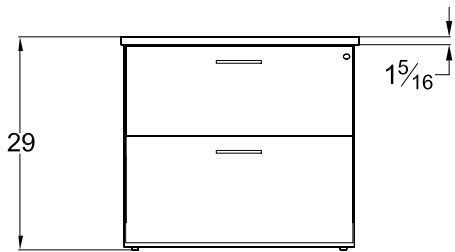

Pedestal Front Profile
Lateral File

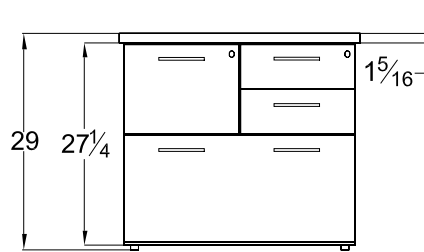

Pedestal Front Profile
Multi-File

COUNTER SUPPORT POST

3" Diameter, 16 gauge steel post. Bolted through lower worksurface. Tops provide rigid counter mounting. Powder coat finish in matte nickel.

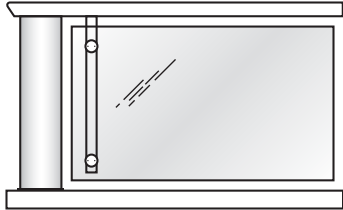

PRIVACY SCREEN DETAIL

Frosted Acrylic panels are suspended between countertops and worksurfaces with matte nickel rods and fasteners. Panels float between support post and surfaces. Panels are curved to match curved surfaces. Edges and corners are rounded.

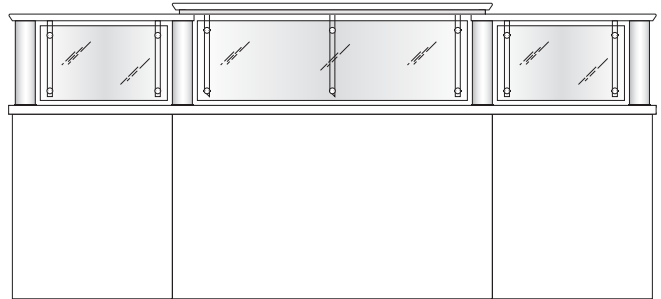

PRIVACY SCREEN DETAIL

Acrylic Screen is fastened to matte nickel rod and sleeve collar with matte nickel screw caps.

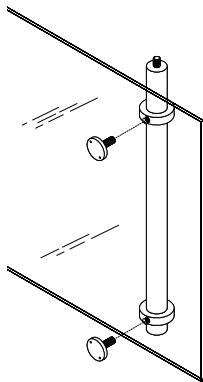

APPROACH VIEW

1" space provides a floating appearance

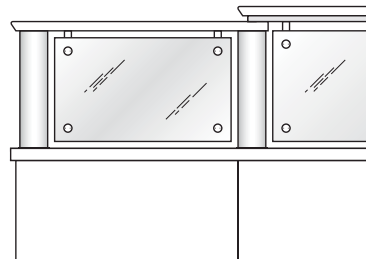

USER VIEW

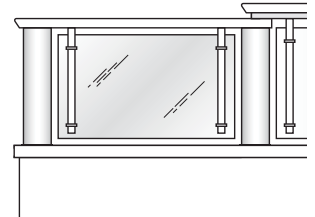

GRAIN DIRECTION

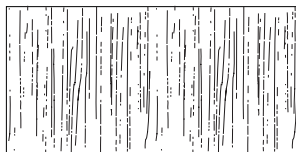

Bridge

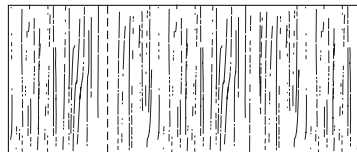

Return



Credenza

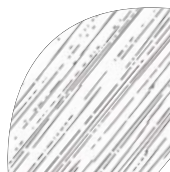

Corner

INTERIOR DRAWER DIMENSIONS

UNIT DEPTH	DRAWER TYPE	OVERALL DIMENSIONS			INTERIOR DRAWER DIMENSIONS		
		W	D	H	W	D	H
15-5/8" Letter	24" Box	13-1/8	16-1/16	4	12-1/8	15-1/16	3-7/16
	24" File	13-1/8	16-1/16	9-13/16	12-1/8	15-1/16	9-5/16
29" Lateral	24" File	26-1/2	16-1/16	9-13/16	25-1/2	15-1/16	9-5/16
35" Lateral	24" File	32-1/2	16-1/16	9-13/16	31-1/2	15-1/16	9-5/16

FILING REFERENCE

FILING FOR 24" DEPTH UNITS

13 1/8" Wide File Drawer - 16 1/16" Deep

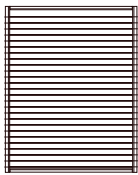

Letter Front to Back

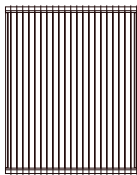

Legal Side to Side
with File Rail

29" LATERAL FILE DRAWER

26-1/2" Wide File Drawer - 16-1/16" Deep

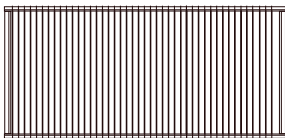

Legal Side to Side

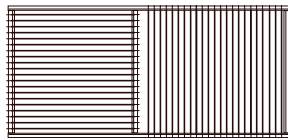

Legal Side to Side
with File Rail

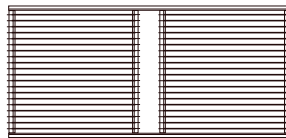

Letter Front to Back
with File Rail

35" LATERAL FILE DRAWER

32-1/2" Wide File Drawer - 16-1/16" Deep

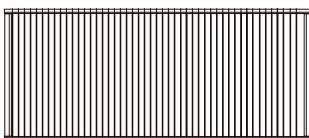

Legal Side to Side

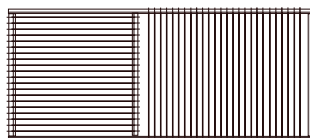

Legal Side to Side
Letter Front to Back
with File Rail

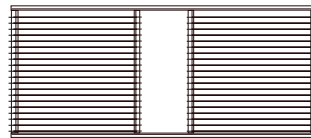

Letter Front to Back
with File Rail

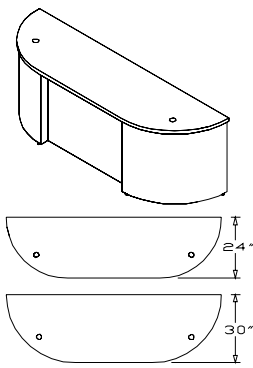

CURVED RECEPTION DESK

STANDARD FEATURES

- 2 Standard grommet - matches pull finish or specify black TM30 or silver TM31
- Storage shelf
- Wire management channels

NOTES

- "U" Reception Stations require minimum 84" to ensure adequate kneespace area.

[CLICK HERE TO VIEW PRODUCT INDEX](#)

1 SELECT A STYLE

DIMENSIONS		STYLE NUMBER	LIST PRICE	STYLE NUMBER	LIST PRICE	STYLE NUMBER	LIST PRICE
W" x D" x H"	WGT	"W" Veneer Top Veneer Chassis		"G" High Pressure Laminate Top HPL Veneer Chassis		"M" Thermally Fused Laminate Top Thermally Fused Laminate Chassis	
30" Depth							
96 x 30 x 29	250	CRP9630DS024W	4742	CRP9630DS024G	4742	"M" Option N/A	
90 x 30 x 29	240	CRP9030DS024W	4273	CRP9030DS024G	4273	"M" Option N/A	
84 x 30 x 29	200	CRP8430DS024W	3954	CRP8430DS024G	3954	"M" Option N/A	
78 x 30 x 29	190	CRP7830DS024W	3729	CRP7830DS024G	3729	"M" Option N/A	
72 x 30 x 29	175	CRP7230DS024W	3486	CRP7230DS024G	3486	"M" Option N/A	
24" Depth							
96 x 24 x 29	210	CRP9624DS024W	4347	CRP9624DS024G	4347	"M" Option N/A	
90 x 24 x 29	200	CRP9024DS024W	3879	CRP9024DS024G	3879	"M" Option N/A	
84 x 24 x 29	170	CRP8424DS024W	3510	CRP8424DS024G	3510	"M" Option N/A	
78 x 24 x 29	160	CRP7824DS024W	3336	CRP7824DS024G	3336	"M" Option N/A	
72 x 24 x 29	150	CRP7224DS024W	3093	CRP7224DS024G	3093	"M" Option N/A	

2 SELECT A FINISH

"W" Veneer	"G" HPL	"M" TFL	
WAC	GAC	-	Amber Cherry
WRC	-	-	Caramel Cherry
WIC	GIC	-	Crimson Cherry
WEC	-	-	Ebony
WHC	GHC	-	Honey Cherry
WOC	GOC	-	KoKo Cherry
WSC	-	-	Scotch Cherry
WCM	GCM	-	Clear Maple
WWM	GWM	-	Wheat Maple
WEW	GEW	-	Executive Walnut
WGW	-	-	Gunstock Walnut
WBW	-	-	Henna Walnut
WJW	-	-	Judicial Walnut
WNW	GNW	-	Natural Walnut

3 SELECT AN EDGE



Flat 3 mm

5 OPTIONS

- ACCESSORIES**
- K18: CPU Retractable Cradle - \$195
 - K28: Articulating Keyboard w/ Mouse - \$375
 - K31: Center Drawer - \$195
- GROMMETS (NON-STANDARD LOCATION)**
- Provide drawing w/ Grommet Location and Specify Color - \$90 ea.
- Black: TM30-NS
 - Silver: TM31-NS

4 SELECT HARDWARE

Hardware Option Not Available

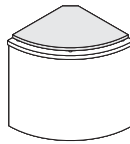
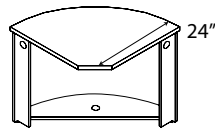
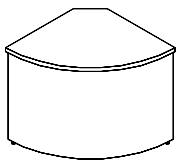

CVC3030 Option

CURVED "V" CORNER

STANDARD FEATURES

- 1 Standard grommet in footrest
- Grommet standard in storage shelf for wire access to the floor
- Storage shelf
- Wire management grommets & channels

NOTES

- For 24"D Return Hookup

[CLICK HERE TO VIEW PRODUCT INDEX](#)

1 SELECT A STYLE

DIMENSIONS		STYLE NUMBER	LIST PRICE	STYLE NUMBER	LIST PRICE	STYLE NUMBER	LIST PRICE
W" x D" x H"	WGT	"W" Veneer Top Veneer Chassis		"G" High Pressure Laminate Top Veneer Chassis		"M" Thermally Fused Laminate Top Thermally Fused Laminate Chassis	
30 x 30 x 29	95	CRP3030CU237W	1793	CRP3030CU237G	1793	"M"Option N/A	

2 SELECT A FINISH

"W" Veneer	"G" HPL	"M" TFL	
WAC	GAC	-	Amber Cherry
WRC	-	-	Caramel Cherry
WIC	GIC	-	Crimson Cherry
WEC	-	-	Ebony
WHC	GHC	-	Honey Cherry
WOC	GOC	-	KoKo Cherry
WSC	-	-	Scotch Cherry
WCM	GCM	-	Clear Maple
WWM	GWM	-	Wheat Maple
WEW	GEW	-	Executive Walnut
WGW	-	-	Gunstock Walnut
WBW	-	-	Henna Walnut
WJW	-	-	Judicial Walnut
WNW	GNW	-	Natural Walnut

3 SELECT AN EDGE



Flat 3 mm

5 OPTIONS

- GROMMETS (STANDARD LOCATION)**
Specify Color and Left/Right/Center - \$45 ea.
- Black: TM30-R (Right), TM30-L (Left), TM30-C (Center)
- Silver: TM31-R (Right), TM31-L (Left), TM31-C (Center)
- GROMMETS (NON-STANDARD LOCATION)**
Provide drawing w/ Grommet Location and Specify Color - \$90 ea.
- Black: TM30-NS
- Silver: TM31-NS
- SOLID SURFACE TOP**
Solid Surface: Black pear G10, sea oat quartz G38, white quartz G4
- SS3030: Curved "V" corner accent top - \$1530
- CV3030: "W" veneer "G" HPL curved "V" corner accent top - \$525

4 SELECT HARDWARE

Hardware
Option Not
Available

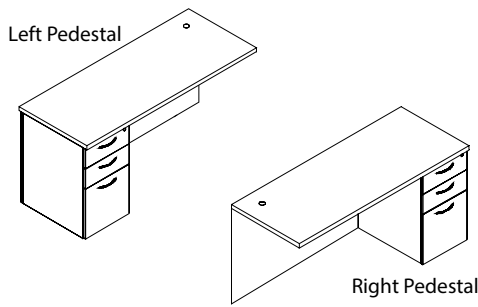

RETURN - BOX/BOX/FILE

STANDARD FEATURES

- 1 Standard grommet - matches pull finish or specify black TM30 or silver TM31
- Full extension drawers - locking
- Full fixed modesty
- Soft close suspension drawer(s)
- Wire management channel

NOTES

- Hinged modesty n/a on reception

[CLICK HERE TO VIEW PRODUCT INDEX](#)

1 SELECT A STYLE

DIMENSIONS		STYLE NUMBER	LIST PRICE	STYLE NUMBER	LIST PRICE	STYLE NUMBER	LIST PRICE
W" x D" x H"	WGT	"W" Veneer Veneer Top Veneer Chassis		"G" HPL High Pressure Laminate Top Veneer Chassis		"M" TFL Thermally Fused Laminate Top Thermally Fused Laminate Chassis	
Left Pedestal							
60 x 24 x 29	175	CRP6024RE207W	2243	CRP6024RE207G	2243	"M" Option N/A	
54 x 24 x 29	165	CRP5424RE207W	2175	CRP5424RE207G	2175	"M" Option N/A	
48 x 24 x 29	155	CRP4824RE207W	2102	CRP4824RE207G	2102	"M" Option N/A	
42 x 24 x 29	145	CRP4224RE207W	2062	CRP4224RE207G	2062	"M" Option N/A	
36 x 24 x 29	135	CRP3624RE207W	2033	CRP3624RE207G	2033	"M" Option N/A	
Right Pedestal							
60 x 24 x 29	175	CRP6024RE209W	2243	CRP6024RE209G	2243	"M" Option N/A	
54 x 24 x 29	165	CRP5424RE209W	2175	CRP5424RE209G	2175	"M" Option N/A	
48 x 24 x 29	155	CRP4824RE209W	2102	CRP4824RE209G	2102	"M" Option N/A	
42 x 24 x 29	145	CRP4224RE209W	2062	CRP4224RE209G	2062	"M" Option N/A	
36 x 24 x 29	135	CRP3624RE209W	2033	CRP3624RE209G	2033	"M" Option N/A	

2 SELECT A FINISH

"W" Veneer	"G" HPL	"M" TFL	
WAC	GAC	-	Amber Cherry
WRC	-	-	Caramel Cherry
WIC	GIC	-	Crimson Cherry
WEC	-	-	Ebony
WHC	GHC	-	Honey Cherry
WOC	GOC	-	KoKo Cherry
WSC	-	-	Scotch Cherry
WCM	GCM	-	Clear Maple
WWM	GWM	-	Wheat Maple
WEW	GEW	-	Executive Walnut
WGW	-	-	Gunstock Walnut
WBW	-	-	Henna Walnut
WJW	-	-	Judicial Walnut
WNW	GNW	-	Natural Walnut

3 SELECT AN EDGE



Flat 3 mm

5 OPTIONS

ACCESSORIES

- K28: Articulating Keyboard w/ Mouse - \$375
- K18: CPU Retractable Cradle - \$195

DRAWERS

- P33: Wood Drawer Upgrade - \$40 per drawer
- P40W: extra Box/Box/File or File/File to Kneespace - \$875

GROMMETS (NON-STANDARD LOCATION)

- Provide drawing w/ Grommet Location and Specify Color - \$90 ea.
- Black: TM30-NS
- Silver: TM31-NS

4 SELECT HARDWARE



PL-105 Matte Black
PL-106 Matte Nickel



PL-112 Matte Black
PL-113 Matte Nickel

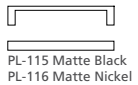

PL-115 Matte Black
PL-116 Matte Nickel

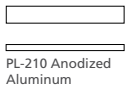

PL-210 Anodized
Aluminum

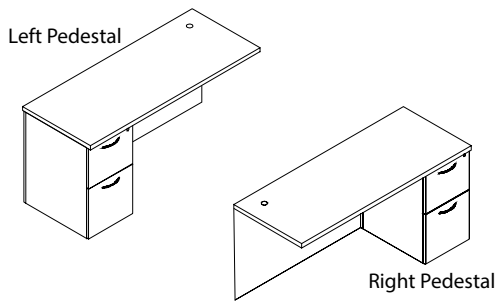

RETURN

STANDARD FEATURES

- 1 Standard grommet - matches pull finish or specify black TM30 or silver TM31
- Full extension drawers - locking
- Full fixed modesty
- Soft close suspension drawer(s)
- Wire management channel

NOTES

- Hinged modesty n/a on reception

[CLICK HERE TO VIEW PRODUCT INDEX](#)

1 SELECT A STYLE

DIMENSIONS		STYLE NUMBER	LIST PRICE	STYLE NUMBER	LIST PRICE	STYLE NUMBER	LIST PRICE
W" x D" x H"	WGT	"W" Veneer Veneer Top Veneer Chassis		"G" HPL High Pressure Laminate Top Veneer Chassis		"M" TFL Thermally Fused Laminate Top Thermally Fused Laminate Chassis	
Left Pedestal							
60 x 24 x 29	175	CRP6024RE195W	2243	CRP6024RE195G	2243	"M" Option N/A	
54 x 24 x 29	165	CRP5424RE195W	2175	CRP5424RE195G	2175	"M" Option N/A	
48 x 24 x 29	155	CRP4824RE195W	2102	CRP4824RE195G	2102	"M" Option N/A	
42 x 24 x 29	145	CRP4224RE195W	2062	CRP4224RE195G	2062	"M" Option N/A	
36 x 24 x 29	135	CRP3624RE195W	2033	CRP3624RE195G	2033	"M" Option N/A	
Right Pedestal							
60 x 24 x 29	175	CRP6024RE196W	2243	CRP6024RE196G	2243	"M" Option N/A	
54 x 24 x 29	165	CRP5424RE196W	2175	CRP5424RE196G	2175	"M" Option N/A	
48 x 24 x 29	155	CRP4824RE196W	2102	CRP4824RE196G	2102	"M" Option N/A	
42 x 24 x 29	145	CRP4224RE196W	2062	CRP4224RE196G	2062	"M" Option N/A	
36 x 24 x 29	135	CRP3624RE196W	2033	CRP3624RE196G	2033	"M" Option N/A	

2 SELECT A FINISH

"W" Veneer	"G" HPL	"M" TFL	
WAC	GAC	-	Amber Cherry
WRC	-	-	Caramel Cherry
WIC	GIC	-	Crimson Cherry
WEC	-	-	Ebony
WHC	GHC	-	Honey Cherry
WOC	GOC	-	KoKo Cherry
WSC	-	-	Scotch Cherry
WCM	GCM	-	Clear Maple
WWM	GWM	-	Wheat Maple
WEW	GEW	-	Executive Walnut
WGW	-	-	Gunstock Walnut
WBW	-	-	Henna Walnut
WJW	-	-	Judicial Walnut
WNW	GNW	-	Natural Walnut

3 SELECT AN EDGE



Flat 3 mm

5 OPTIONS

ACCESSORIES

- K28: Articulating Keyboard w/ Mouse - \$375
- K18: CPU Retractable Cradle - \$195

DRAWERS

- P33: Wood Drawer Upgrade - \$40 per drawer
- P40W: extra Box/Box/File or File/File to Kneespace - \$875

GROMMETS (NON-STANDARD LOCATION)

- Provide drawing w/ Grommet Location and Specify Color - \$90 ea.
- Black: TM30-NS
- Silver: TM31-NS

4 SELECT HARDWARE



PL-105 Matte Black
PL-106 Matte Nickel



PL-112 Matte Black
PL-113 Matte Nickel

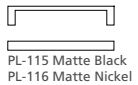

PL-115 Matte Black
PL-116 Matte Nickel

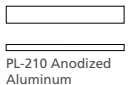

PL-210 Anodized
Aluminum

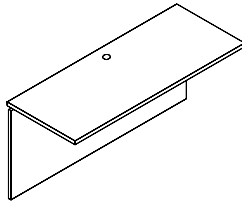

BRIDGE

STANDARD FEATURES

- Full fixed modesty
- 1 Standard grommet - matches pull finish or specify black TM30 or silver TM31

[CLICK HERE TO VIEW PRODUCT INDEX](#)

1 SELECT A STYLE

DIMENSIONS		STYLE NUMBER	LIST PRICE	STYLE NUMBER	LIST PRICE	STYLE NUMBER	LIST PRICE
"W" x "D" x "H"	WGT	"W" Veneer Veneer Top Veneer Chassis		"G" HPL High Pressure Laminate Top Veneer Chassis		"M" TFL Thermally Fused Laminate Top Thermally Fused Laminate Chassis	
72 x 24 x 29	145	CRP7224BR150W	1193	CRP7224BR150G	1193	"M"Option N/A	
66 x 24 x 29	120	CRP6624BR150W	1063	CRP6624BR150G	1063	"M" Option N/A	
60 x 24 x 29	105	CRP6024BR150W	931	CRP6024BR150G	931	"M" Option N/A	
54 x 24 x 29	100	CRP5424BR150W	775	CRP5424BR150G	775	"M" Option N/A	
48 x 24 x 29	90	CRP4824BR150W	713	CRP4824BR150G	713	"M" Option N/A	
42 x 24 x 29	85	CRP4224BR150W	688	CRP4224BR150G	688	"M" Option N/A	

2 SELECT A FINISH

"W" Veneer	"G" HPL	"M" TFL	
WAC	GAC	-	Amber Cherry
WRC	-	-	Caramel Cherry
WIC	GIC	-	Crimson Cherry
WEC	-	-	Ebony
WHC	GHC	-	Honey Cherry
WOC	GOC	-	KoKo Cherry
WSC	-	-	Scotch Cherry
WCM	GCM	-	Clear Maple
WWM	GWM	-	Wheat Maple
WEW	GEW	-	Executive Walnut
WGW	-	-	Gunstock Walnut
WBW	-	-	Henna Walnut
WJW	-	-	Judicial Walnut
WNW	GNW	-	Natural Walnut

3 SELECT AN EDGE



5 OPTIONS

- ACCESSORIES**
- K28: Articulating Keyboard w/ Mouse - \$375
 - K18: CPU Retractable Cradle - \$195
- GROMMETS (NON-STANDARD LOCATION)**
- Provide drawing w/ Grommet Location and Specify Color - \$90 ea.
- Black: TM30-NS
 - Silver: TM31-NS
- MODESTY**
- M34T: "W" "G" Style Drop Door Tech Modesty - \$125
 - M51: Open Back Modesty with Wire Mgmt Rail - Deduct \$95

4 SELECT HARDWARE

Hardware
Option Not
Available

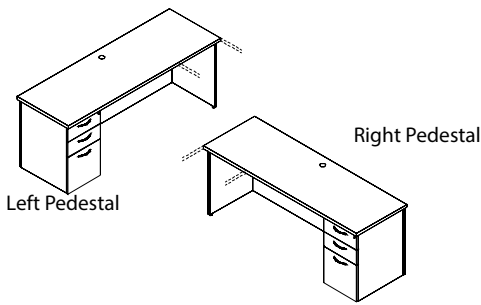

BOX/BOX/FILE

STANDARD FEATURES

- Full extension drawers - locking
- Fully finished back for open plan
- Full veneer modesty
- 1 Standard grommet - matches pull finish or specify black TM30 or silver TM31
- Soft close suspension drawer(s)

NOTES

- Keyboard not available on 60" units.

[CLICK HERE TO VIEW PRODUCT INDEX](#)

1 SELECT A STYLE

DIMENSIONS		STYLE NUMBER	LIST PRICE	STYLE NUMBER	LIST PRICE	STYLE NUMBER	LIST PRICE
W" x D" x H"	WGT	"W" Veneer Veneer Top Veneer Chassis		"G" HPL High Pressure Laminate Top Veneer Chassis		"M" TFL Thermally Fused Laminate Top Thermally Fused Laminate Chassis	
Left Pedestal							
84 x 24 x 29	250	CRP8424CA936W	2780	CRP8424CA936G	2780	"M" Option N/A	
72 x 24 x 29	240	CRP7224CA936W	2460	CRP7224CA936G	2460	"M" Option N/A	
66 x 24 x 29	225	CRP6624CA936W	2413	CRP6624CA936G	2413	"M" Option N/A	
60 x 24 x 29	210	CRP6024CA936W	2399	CRP6024CA936G	2399	"M" Option N/A	
Right Pedestal							
84 x 24 x 29	250	CRP8424CA937W	2780	CRP8424CA937G	2780	"M" Option N/A	
72 x 24 x 29	240	CRP7224CA937W	2460	CRP7224CA937G	2460	"M" Option N/A	
66 x 24 x 29	225	CRP6624CA937W	2413	CRP6624CA937G	2413	"M" Option N/A	
60 x 24 x 29	210	CRP6024CA937W	2399	CRP6024CA937G	2399	"M" Option N/A	

2 SELECT A FINISH

"W" Veneer	"G" HPL	"M" TFL	
WAC	GAC	-	Amber Cherry
WRC	-	-	Caramel Cherry
WIC	GIC	-	Crimson Cherry
WEC	-	-	Ebony
WHC	GHC	-	Honey Cherry
WOC	GOC	-	KoKo Cherry
WSC	-	-	Scotch Cherry
WCM	GCM	-	Clear Maple
WWM	GWM	-	Wheat Maple
WEW	GEW	-	Executive Walnut
WGW	-	-	Gunstock Walnut
WBW	-	-	Henna Walnut
WJW	-	-	Judicial Walnut
WNW	GNW	-	Natural Walnut

3 SELECT AN EDGE



5 OPTIONS

ACCESSORIES

- K28: Articulating Keyboard w/ Mouse - \$375
- K18: CPU Retractable Cradle - \$195

DRAWERS

- P33: Wood Drawer Upgrade - \$40 per drawer
- P40W: extra Box/Box/File or File/File to Kneespace - \$875

GROMMETS (NON-STANDARD LOCATION)

- Provide drawing w/ Grommet Location and Specify Color - \$90 ea.
- Black: TM30-N5
- Silver: TM31-N5

MODESTY

- M34T: "W" "G" Style Drop Door Tech Modesty - \$125
- M51: Open Back Modesty with Wire Mgmt Rail - Deduct \$95

4 SELECT HARDWARE

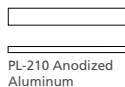
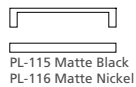
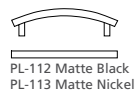

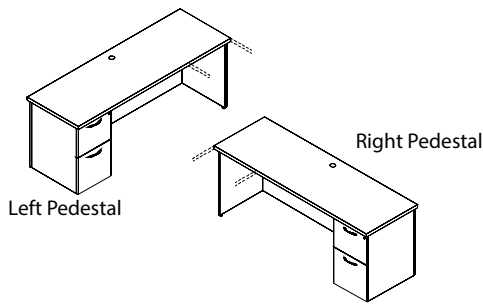

FILE/FILE

STANDARD FEATURES

- Full extension drawers - locking
- Fully finished back for open plan
- Full veneer modesty
- 1 Standard grommet - matches pull finish or specify black TM30 or silver TM31
- Soft close suspension drawer(s)

NOTES

- Keyboard not available on 60" units.

[CLICK HERE TO VIEW PRODUCT INDEX](#)

1 SELECT A STYLE

DIMENSIONS		STYLE NUMBER	LIST PRICE	STYLE NUMBER	LIST PRICE	STYLE NUMBER	LIST PRICE
W" x D" x H"	WGT	"W" Veneer Veneer Top Veneer Chassis		"G" HPL High Pressure Laminate Top Veneer Chassis		"M" TFL Thermally Fused Laminate Top Thermally Fused Laminate Chassis	
Left Pedestal							
84 x 24 x 29	250	CRP8424CA938W	2780	CRP8424CA938G	2780	"M" Option N/A	
72 x 24 x 29	240	CRP7224CA938W	2460	CRP7224CA938G	2460	"M" Option N/A	
66 x 24 x 29	225	CRP6624CA938W	2413	CRP6624CA938G	2413	"M" Option N/A	
60 x 24 x 29	210	CRP6024CA938W	2399	CRP6024CA938G	2399	"M" Option N/A	
Right Pedestal							
84 x 24 x 29	250	CRP8424CA939W	2780	CRP8424CA939G	2780	"M" Option N/A	
72 x 24 x 29	240	CRP7224CA939W	2460	CRP7224CA939G	2460	"M" Option N/A	
66 x 24 x 29	225	CRP6624CA939W	2413	CRP6624CA939G	2413	"M" Option N/A	
60 x 24 x 29	210	CRP6024CA939W	2399	CRP6024CA939G	2399	"M" Option N/A	

2 SELECT A FINISH

"W" Veneer	"G" HPL	"M" TFL	
WAC	GAC	-	Amber Cherry
WRC	-	-	Caramel Cherry
WIC	GIC	-	Crimson Cherry
WEC	-	-	Ebony
WHC	GHC	-	Honey Cherry
WOC	GOC	-	KoKo Cherry
WSC	-	-	Scotch Cherry
WCM	GCM	-	Clear Maple
WWM	GWM	-	Wheat Maple
WEW	GEW	-	Executive Walnut
WGW	-	-	Gunstock Walnut
WBW	-	-	Henna Walnut
WJW	-	-	Judicial Walnut
WNW	GNW	-	Natural Walnut

3 SELECT AN EDGE



5 OPTIONS

ACCESSORIES

- K28: Articulating Keyboard w/ Mouse - \$375
- K18: CPU Retractable Cradle - \$195

DRAWERS

- P33: Wood Drawer Upgrade - \$40 per drawer
- P40W: extra Box/Box/File or File/File to Kneespace - \$875

GROMMETS (STANDARD LOCATION)

- Specify Color - \$45 ea.
- Black: TM30-C (Center)
- Silver: TM31-C (Center)

GROMMETS (NON-STANDARD LOCATION)

- Provide drawing w/ Grommet Location and Specify Color - \$90 ea.
- Black: TM30-NS
- Silver: TM31-NS

MODESTY

- M34T: "W" "G" Style Drop Door Tech Modesty - \$125
- M51: Open Back Modesty with Wire Mgmt Rail - Deduct \$95

4 SELECT HARDWARE

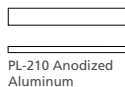
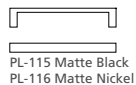
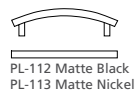

RECEPTION WORKSTATION CREDENZA

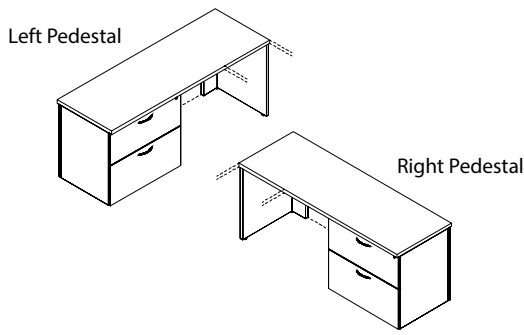

"U" WORKSTATION CREDENZA - LATERAL FILE

STANDARD FEATURES

- Full extension drawers - locking
- Fully finished for open plan
- Full veneer modesty
- 1 Standard grommet - matches pull finish or specify black TM30 or silver TM31

NOTES

- Keyboard not available on 60", 66", 70" units.

[CLICK HERE TO VIEW PRODUCT INDEX](#)

1 SELECT A STYLE

DIMENSIONS		STYLE NUMBER	LIST PRICE	STYLE NUMBER	LIST PRICE	STYLE NUMBER	LIST PRICE
W" x D" x H"	WGT	"W" Veneer Veneer Top Veneer Chassis		"G" HPL High Pressure Laminate Top Veneer Chassis		"M" TFL Thermally Fused Laminate Top Thermally Fused Laminate Chassis	
Left Pedestal							
96 x 24 x 29	280	CRP9624CA940W	3313	CRP9624CA940G	3313	"M" Option N/A	
84 x 24 x 29	260	CRP8424CA940W	3101	CRP8424CA940G	3101	"M" Option N/A	
72 x 24 x 29	255	CRP7224CA940W	2808	CRP7224CA940G	2808	"M" Option N/A	
66 x 24 x 29	220	CRP6624CA940W	2767	CRP6624CA940G	2767	"M" Option N/A	
60 x 24 x 29	200	CRP6024CA940W	2754	CRP6024CA940G	2754	"M" Option N/A	
Right Pedestal							
96 x 24 x 29	280	CRP9624CA941W	3313	CRP9624CA941G	3313	"M" Option N/A	
84 x 24 x 29	260	CRP8424CA941W	3101	CRP8424CA941G	3101	"M" Option N/A	
72 x 24 x 29	255	CRP7224CA941W	2808	CRP7224CA941G	2808	"M" Option N/A	
66 x 24 x 29	220	CRP6624CA941W	2767	CRP6624CA941G	2767	"M" Option N/A	
60 x 24 x 29	200	CRP6024CA941W	2754	CRP6024CA941G	2754	"M" Option N/A	

2 SELECT A FINISH

"W" Veneer	"G" HPL	"M" TFL	
WAC	GAC	-	Amber Cherry
WRC	-	-	Caramel Cherry
WIC	GIC	-	Crimson Cherry
WEC	-	-	Ebony
WHC	GHC	-	Honey Cherry
WOC	GOC	-	KoKo Cherry
WSC	-	-	Scotch Cherry
WCM	GCM	-	Clear Maple
WWM	GWM	-	Wheat Maple
WEW	GEW	-	Executive Walnut
WGW	-	-	Gunstock Walnut
WBW	-	-	Henna Walnut
WJW	-	-	Judicial Walnut
WNW	GNW	-	Natural Walnut

3 SELECT AN EDGE



5 OPTIONS

ACCESSORIES

- K28: Articulating Keyboard w/ Mouse - \$375
- K18: CPU Retractable Cradle - \$195

DRAWERS

- P33: Wood Drawer Upgrade - \$40 per drawer
- P40W: extra Box/Box/File or File/File to Kneespace - \$875 (N/A on 60" W)

GROMMETS (STANDARD LOCATION)

- Specify Color - \$45 ea.
- Black: TM30-C (Center)
- Silver: TM31-C (Center)

GROMMETS (NON-STANDARD LOCATION)

- Provide drawing w/ Grommet Location and Specify Color - \$90 ea.
- Black: TM30-NS
- Silver: TM31-NS

MODESTY

- M34T: "W" "G" Style Drop Door Tech Modesty - \$125
- M51: Open Back Modesty with Wire Mgmt Rail - Deduct \$95

4 SELECT HARDWARE

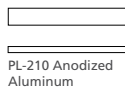
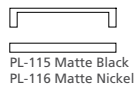
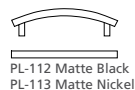
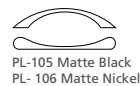

Box/Box/File



File/File

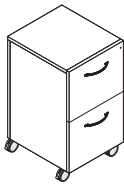

Box/File



OPEN PLAN MOBILE PEDESTAL

STANDARD FEATURES

- Finished all sides and top
- Full extension drawers - locking
- Soft close suspension drawer(s)

NOTES

- Pedestal Cushion can be specified on all pedestals, but on Box/ Box/ File and File/File unit will not fit under work surface w/ cushion.

[CLICK HERE TO VIEW PRODUCT INDEX](#)

1 SELECT A STYLE

DIMENSIONS		STYLE NUMBER	LIST PRICE	STYLE NUMBER	LIST PRICE	STYLE NUMBER	LIST PRICE
W" x D" x H"	WGT	"W" Veneer Veneer Top Veneer Chassis		"G" HPL High Pressure Laminate Top Veneer Chassis		"M" TFL Thermally Fused Laminate Top Thermally Fused Laminate Chassis	
Box/Box/File							
16 x 18 x 27	70	CRP1618PD424W	1092	"G" option N/A		"M" Option N/A	
File/File							
16 x 18 x 27	70	CRP1618PD425W	1092	"G" option N/A		"M" Option N/A	
Box/File							
16 x 18 x 23	55	CRP1618PD423W	1008	"G" Option N/A		"M" Option N/A	

BC16 Cushion Option (Choose Grade Below)

COM	COL	1	2	3	4	5	6	7	8	9	10	11/ L1	12	13/ L2
190	210	235	250	265	280	295	310	325	340	355	370	385	400	430

2 SELECT A FINISH

"W" Veneer	"G" HPL	"M" TFL	
WAC	GAC	-	Amber Cherry
WRC	-	-	Caramel Cherry
WIC	GIC	-	Crimson Cherry
WEC	-	-	Ebony
WHC	GHC	-	Honey Cherry
WOC	GOC	-	KoKo Cherry
WSC	-	-	Scotch Cherry
WCM	GCM	-	Clear Maple
WWM	GWM	-	Wheat Maple
WEW	GEW	-	Executive Walnut
WGW	-	-	Gunstock Walnut
WBW	-	-	Henna Walnut
WJW	-	-	Judicial Walnut
WNW	GNW	-	Natural Walnut

3 SELECT AN EDGE

Edge Profile
Option Not Available

5 OPTIONS

- CUSHION**
- BC16: Bench Cushion
 - Specify fabric grade (1 yd. required)
 - Pedestal can not nest under desk when cushion is added
- DRAWER**
- P33: Wood Drawer Upgrade - \$40 per drawer

4 SELECT HARDWARE

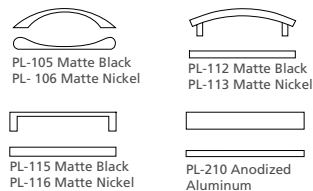

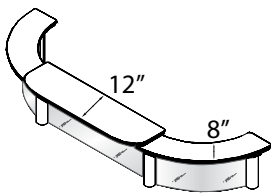

CURVED DESK 12"/8" COUNTER

STANDARD FEATURES

- 3" Silver counter posts standard
- Countertop 1-5/16" veneer (Knife edge profile)
- Frosted acrylic privacy screen w/ metal rods & caps

- "U" & "V" Counter Assemblies Cannot Be Mixed.
- Veneer Countertops Can Be Specified In Different Veneer & Finish From Chassis

NOTES

- 4" Overhang To Front
- (4) posts
- Decorative Acrylic Privacy Screen - Contact Customer Service For Quote.

[CLICK HERE TO VIEW PRODUCT INDEX](#)

1 SELECT A STYLE

DIMENSIONS		STYLE NUMBER	LIST PRICE	STYLE NUMBER	LIST PRICE	STYLE NUMBER	LIST PRICE
W" x D" x H"	WGT	"W" Veneer Veneer Top Veneer Chassis		"G" HPL High Pressure Laminate Top Veneer Chassis		"M" TFL Thermally Fused Laminate Top Thermally Fused Laminate Chassis	
For Desk Sizes 24"D :							
96 x 24 x 18	65	CRP9624TC224W	3603	CRP9624TC224G	3603	"M" Option N/A	
90 x 24 x 18	60	CRP9024TC224W	3398	CRP9024TC224G	3398	"M" Option N/A	
84 x 24 x 18	60	CRP8424TC224W	3184	CRP8424TC224G	3184	"M" Option N/A	
78 x 24 x 18	55	CRP7824TC224W	3057	CRP7824TC224G	3057	"M" Option N/A	
72 x 24 x 18	55	CRP7224TC224W	2990	CRP7224TC224G	2990	"M" Option N/A	
For Desk Sizes 30"D :							
96 x 30 x 18	70	CRP9630TC224W	3660	CRP9630TC224G	3660	"M" Option N/A	
90 x 30 x 18	65	CRP9030TC224W	3455	CRP9030TC224G	3455	"M" Option N/A	
84 x 30 x 18	65	CRP8430TC224W	3241	CRP8430TC224G	3241	"M" Option N/A	
78 x 30 x 18	60	CRP7830TC224W	3113	CRP7830TC224G	3113	"M" Option N/A	
72 x 30 x 18	60	CRP7230TC224W	3047	CRP7230TC224G	3047	"M" Option N/A	

2 SELECT A FINISH

"W" Veneer	"G" HPL	"M" TFL	
WAC	GAC	-	Amber Cherry
WRC	-	-	Caramel Cherry
WIC	GIC	-	Crimson Cherry
WEC	-	-	Ebony
WHC	GHC	-	Honey Cherry
WOC	GOC	-	KoKo Cherry
WSC	-	-	Scotch Cherry
WCM	GCM	-	Clear Maple
WWM	GWM	-	Wheat Maple
WEW	GEW	-	Executive Walnut
WGW	-	-	Gunstock Walnut
WBW	-	-	Henna Walnut
WJW	-	-	Judicial Walnut
WNW	GNW	-	Natural Walnut

3 SELECT AN EDGE



5 OPTIONS

SOLID SURFACE TOP - FOR DESK SIZES 24" D (FLAT EDGE ONLY)

- Solid Surface: Black Pearl G10, Sea Oat Quartz G38, White Quartz G4
- SS9624: For desk size 96 x 24 - \$2225
- SS9024: for desk size 90 x 24 - \$1950
- SS8424: For desk size 84 x 24 - \$1875
- SS7824: For desk size 78 x 24 - \$1875
- SS7224: For desk size 72 x 24 - \$1755

SOLID SURFACE TOP - FOR DESK SIZES 30" D (FLAT EDGE ONLY)

- Solid Surface: Black Pearl G10, Sea Oat Quartz G38, White Quartz G4
- SS9630: For desk size 96 x 30 - \$2455
- SS9030: For desk size 90 x 30 - \$2185
- SS8430: For desk size 84 x 30 - \$2105
- SS7830: For desk size 78 x 30 - \$2105
- SS7230: For desk size 72 x 30 - \$1990

4 SELECT HARDWARE

Hardware
Option Not
Available

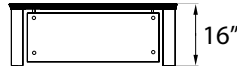
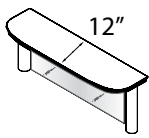

DESK 12" HALF COUNTER

STANDARD FEATURES

- 3" Silver counter posts standard
- Countertop 1-5/16" veneer (Knife edge profile)
- Frosted acrylic privacy screen w/ metal rods & caps

- Desk half counter can only be used as a freestanding unit
- Veneer Countertops Can Be Specified In Different Veneer & Finish From Chassis

NOTES

- 4" Overhang To Front
- (2) posts
- Decorative Acrylic Privacy Screen - Contact Customer Service For Quote.

[CLICK HERE TO VIEW PRODUCT INDEX](#)

1 SELECT A STYLE

DIMENSIONS		STYLE NUMBER	LIST PRICE	STYLE NUMBER	LIST PRICE	STYLE NUMBER	LIST PRICE
W" x D" x H"	WGT	"W" Veneer Veneer Top Veneer Chassis		"G" HPL High Pressure Laminate Top Veneer Chassis		"M" TFL Thermally Fused Laminate Top Thermally Fused Laminate Chassis	
53 x 12 x 16	35	CRP5312TC504W	1962	CRP5312TC504G	1962	"M" Option N/A	
47" Counter for 90" Desk							
47 x 12 x 16	30	CRP4712TC504W	1763	CRP4712TC504G	1763	"M" Option N/A	
41" Counter for 84" Desk							
41 x 12 x 16	30	CRP4112TC504W	1672	CRP4112TC504G	1672	"M" Option N/A	
35" Counter for 78" Desk							
35 x 12 x 16	25	CRP3512TC504W	1580	CRP3512TC504G	1580	"M" Option N/A	
29" Counter for 72" Desk							
29 x 12 x 16	25	CRP2912TC504W	1518	CRP2912TC504G	1518	"M" Option N/A	
23" Counter for 66" Desk							
23 x 12 x 16	20	CRP2312TC504W	1452	CRP2312TC504G	1452	"M" Option N/A	

2 SELECT A FINISH

"W" Veneer	"G" HPL	"M" TFL	
WAC	GAC	-	Amber Cherry
WRC	-	-	Caramel Cherry
WIC	GIC	-	Crimson Cherry
WEC	-	-	Ebony
WHC	GHC	-	Honey Cherry
WOC	GOC	-	KoKo Cherry
WSC	-	-	Scotch Cherry
WCM	GCM	-	Clear Maple
WWM	GWM	-	Wheat Maple
WEW	GEW	-	Executive Walnut
WGW	-	-	Gunstock Walnut
WBW	-	-	Henna Walnut
WJW	-	-	Judicial Walnut
WNV	GNV	-	Natural Walnut

3 SELECT AN EDGE



5 OPTIONS

SOLID SURFACE TOP (FLAT EDGE ONLY)

- Solid Surface: Black Pearl G10, Sea Oat Quartz G38, White Quartz G4
- S5312: For counter size 53 x 12 - \$975
- S54712: For counter size 47 x 12 - \$700
- S54112: For counter size 41 x 12 - \$625
- S53512: For counter size 35 x 12 - \$625
- S52912: For counter size 29 x 12 - \$510
- S52312: For counter size 23 x 12 - \$375

4 SELECT HARDWARE

Hardware
Option Not
Available

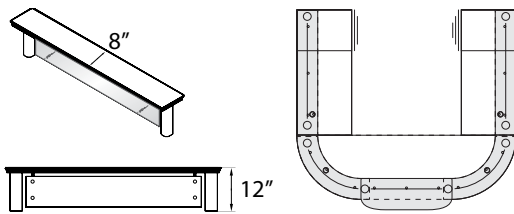

"L" AND "U" RETURN 8" COUNTER

STANDARD FEATURES

- 3" Silver counter posts standard
- Countertop 1-5/16" veneer (Knife edge profile)
- Frosted acrylic privacy screen w/ metal rods & caps

Customer Service For Quote.

- "L" Return counter can only be used with TC224 SKUs
- Veneer Countertops Can Be Specified In Different Veneer & Finish From Chassis

NOTES

- 8" Counter Is Flush To Outside Edge of Return
- (3) posts for 72"-60" W counters, (2) posts for 54"-36" W counters
- Decorative Acrylic Privacy Screen - Contact

[CLICK HERE TO VIEW PRODUCT INDEX](#)

1 SELECT A STYLE

DIMENSIONS		STYLE NUMBER	LIST PRICE	STYLE NUMBER	LIST PRICE	STYLE NUMBER	LIST PRICE
W" x D" x H"	WGT	"W" Veneer Top Veneer Chassis		"G" HPL High Pressure Laminate Top Veneer Chassis		"M" TFL Thermally Fused Laminate Top Thermally Fused Laminate Chassis	
Left Return							
72 x 8 x 12	40	CRP7208TC464W	2407	CRP7208TC464G	2407	"M" Option N/A	
66 x 8 x 12	35	CRP6608TC464W	2280	CRP6608TC464G	2280	"M" Option N/A	
60 x 8 x 12	35	CRP6008TC464W	2024	CRP6008TC464G	2024	"M" Option N/A	
54 x 8 x 12	30	CRP5408TC464W	1836	CRP5408TC464G	1836	"M" Option N/A	
48 x 8 x 12	30	CRP4808TC464W	1635	CRP4808TC464G	1635	"M" Option N/A	
42 x 8 x 12	25	CRP4208TC464W	1508	CRP4208TC464G	1508	"M" Option N/A	
36 x 8 x 12	25	CRP3608TC464W	1370	CRP3608TC464G	1370	"M" Option N/A	
Right Return							
72 x 8 x 12	40	CRP7208TC465W	2407	CRP7208TC465G	2407	"M" Option N/A	
66 x 8 x 12	35	CRP6608TC465W	2280	CRP6608TC465G	2280	"M" Option N/A	
60 x 8 x 12	35	CRP6008TC465W	2024	CRP6008TC465G	2024	"M" Option N/A	
54 x 8 x 12	30	CRP5408TC465W	1836	CRP5408TC465G	1836	"M" Option N/A	
48 x 8 x 12	30	CRP4808TC465W	1635	CRP4808TC465G	1635	"M" Option N/A	
42 x 8 x 12	25	CRP4208TC465W	1508	CRP4208TC465G	1508	"M" Option N/A	
36 x 8 x 12	25	CRP3608TC465W	1370	CRP3608TC465G	1370	"M" Option N/A	

2 SELECT A FINISH

"W" Veneer	"G" HPL	"M" TFL	
WAC	GAC	-	Amber Cherry
WRC	-	-	Caramel Cherry
WIC	GIC	-	Crimson Cherry
WEC	-	-	Ebony
WHC	GHC	-	Honey Cherry
WOC	GOC	-	KoKo Cherry
WSC	-	-	Scotch Cherry
WCM	GCM	-	Clear Maple
WWM	GWM	-	Wheat Maple
WEW	GEW	-	Executive Walnut
WGW	-	-	Gunstock Walnut
WBW	-	-	Henna Walnut
WJW	-	-	Judicial Walnut
WNW	GNW	-	Natural Walnut

3 SELECT AN EDGE



5 OPTIONS

SOLID SURFACE TOP (FLAT EDGE ONLY)

- Solid Surface: Black Pearl G10, Sea Oat Quartz G38, White Quartz G4
- SS7208: For return size 72 x 08 - \$4975
- SS6608: For return size 66 x 08 - \$975
- SS6008: For return size 60 x 08 - \$840
- SS5408: For return size 54 x 08 - \$700
- SS4808: For return size 48 x 08 - \$700
- SS4208: For return size 42 x 08 - \$625
- SS3608: For return size 36 x 08 - \$490

4 SELECT HARDWARE

Hardware
Option Not
Available

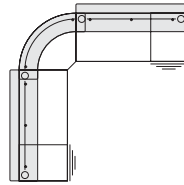
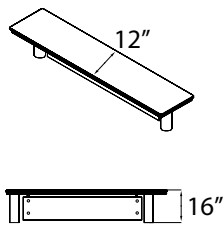

"V" RETURN 12" COUNTER

STANDARD FEATURES

- 3" Silver counter posts standard
- Countertop 1-5/16" veneer (Knife edge profile)
- Frosted acrylic privacy screen w/ metal rods & caps

Mixed.

- Veneer Countertops Can Be Specified In Different Veneer & Finish From Chassis

NOTES

- (2 or 3) posts
- Decorative Acrylic Privacy Screen - Contact Customer Service For Quote.
- "U" & "V" Counter Assemblies Cannot Be

[CLICK HERE TO VIEW PRODUCT INDEX](#)

1 SELECT A STYLE

DIMENSIONS		STYLE NUMBER	LIST PRICE	STYLE NUMBER	LIST PRICE	STYLE NUMBER	LIST PRICE
W" x D" x H"	WGT	"W" Veneer Top Veneer Chassis		"G" HPL High Pressure Laminate Top Veneer Chassis		"M" TFL Thermally Fused Laminate Top Thermally Fused Laminate Chassis	
Left Return							
72 x 12 x 16	50	CRP7212TC467W	2535	CRP7212TC467G	2535	"M" Option N/A	
66 x 12 x 16	45	CRP6612TC467W	2407	CRP6612TC467G	2407	"M" Option N/A	
60 x 12 x 16	45	CRP6012TC467W	2151	CRP6012TC467G	2151	"M" Option N/A	
54 x 12 x 16	40	CRP5412TC467W	1962	CRP5412TC467G	1962	"M" Option N/A	
48 x 12 x 16	30	CRP4812TC467W	1763	CRP4812TC467G	1763	"M" Option N/A	
42 x 12 x 16	30	CRP4212TC467W	1635	CRP4212TC467G	1635	"M" Option N/A	
36 x 12 x 16	25	CRP3612TC467W	1508	CRP3612TC467G	1508	"M" Option N/A	
Right Return							
72 x 12 x 16	50	CRP7212TC468W	2535	CRP7212TC468G	2535	"M" Option N/A	
66 x 12 x 16	45	CRP6612TC468W	2407	CRP6612TC468G	2407	"M" Option N/A	
60 x 12 x 16	45	CRP6012TC468W	2151	CRP6012TC468G	2151	"M" Option N/A	
54 x 12 x 16	40	CRP5412TC468W	1962	CRP5412TC468G	1962	"M" Option N/A	
48 x 12 x 16	30	CRP4812TC468W	1763	CRP4812TC468G	1763	"M" Option N/A	
42 x 12 x 16	30	CRP4212TC468W	1635	CRP4212TC468G	1635	"M" Option N/A	
36 x 12 x 16	25	CRP3612TC468W	1508	CRP3612TC468G	1508	"M" Option N/A	

2 SELECT A FINISH

"W" Veneer	"G" HPL	"M" TFL	
WAC	GAC	-	Amber Cherry
WRC	-	-	Caramel Cherry
WIC	GIC	-	Crimson Cherry
WEC	-	-	Ebony
WHC	GHC	-	Honey Cherry
WOC	GOC	-	KoKo Cherry
WSC	-	-	Scotch Cherry
WCM	GCM	-	Clear Maple
WWM	GWM	-	Wheat Maple
WEW	GEW	-	Executive Walnut
WGW	-	-	Gunstock Walnut
WBW	-	-	Henna Walnut
WJW	-	-	Judicial Walnut
WNW	GNW	-	Natural Walnut

3 SELECT AN EDGE



5 OPTIONS

SOLID SURFACE TOP

- Solid Surface: Black Pearl G10, Sea Oat Quartz G38, White Quartz G4
- SS7212: For return size 72 x 12 - \$975
- SS6612: For return size 66 x 12 - \$975
- SS6012: For return size 60 x 12 - \$840
- SS5412: For return size 54 x 12 - \$700
- SS4812: For return size 48 x 12 - \$700
- SS4212: For return size 42 x 12 - \$625
- SS3612: For return size 36 x 12 - \$490

4 SELECT HARDWARE

Hardware
Option Not
Available

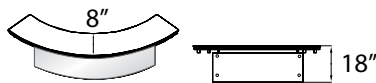

"V" BRIDGE CORNER COUNTER

STANDARD FEATURES

- Countertop 1-5/16" veneer (Knife edge profile)
- Frosted acrylic privacy screen w/ metal rods & caps

- "V" Bridge corner counter can only be used with TC467 and TC468 SKUs
- Veneer Countertops Can Be Specified In Different Veneer & Finish From Chassis

NOTES

- 8" Wide Counter
- Decorative Acrylic Privacy Screen - Contact Customer Service For Quote.
- "U" & "V" Counter Assemblies Cannot Be Mixed.

[CLICK HERE TO VIEW PRODUCT INDEX](#)

1 SELECT A STYLE

DIMENSIONS		STYLE NUMBER	LIST PRICE	STYLE NUMBER	LIST PRICE	STYLE NUMBER	LIST PRICE
W" x D" x H"	WGHT	"W" Veneer Top Veneer Veneer Chassis		"G" High Pressure Laminate Top HPL Veneer Chassis		"M" Thermally Fused Laminate Top TFL Thermally Fused Laminate Chassis	
30 x 30 x 18	15	CRP3030TC471W	818	CRP3030TC471G	818	"M" Option N/A	

2 SELECT A FINISH

"W" Veneer	"G" HPL	"M" TFL	
WAC	GAC	-	Amber Cherry
WRC	-	-	Caramel Cherry
WIC	GIC	-	Crimson Cherry
WEC	-	-	Ebony
WHC	GHC	-	Honey Cherry
WOC	GOC	-	KoKo Cherry
WSC	-	-	Scotch Cherry
WCM	GCM	-	Clear Maple
WWM	GWM	-	Wheat Maple
WEW	GEW	-	Executive Walnut
WGW	-	-	Gunstock Walnut
WBW	-	-	Henna Walnut
WJW	-	-	Judicial Walnut
WNW	GNW	-	Natural Walnut

3 SELECT AN EDGE



5 OPTIONS

SOLID SURFACE TOP (FLAT EDGE ONLY)

- Solid Surface: Black Pearl G10, Sea Oat Quartz G38, White Quartz G4
- SS3030: For bridge size 30 x 30 - \$750

4 SELECT HARDWARE

Hardware
Option Not
Available

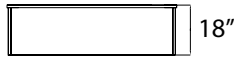

18" "V" CORNER COUNTER SHELL

STANDARD FEATURES

- 3/4" Curved Wood Back Panel
- Countertop 1-5/16" veneer (Knife edge profile)

NOTES

- 3/4" Thick Counter Shell Back Is Suitable For Signage Application
- "U" & "V" Counter Assemblies Cannot Be Mixed.
- Veneer Countertops Can Be Specified In Different Veneer & Finish From Chassis

[CLICK HERE TO VIEW PRODUCT INDEX](#)

1 SELECT A STYLE

DIMENSIONS	STYLE NUMBER	LIST PRICE	STYLE NUMBER	LIST PRICE	STYLE NUMBER	LIST PRICE
W" x D" x H" 30 x 30 x 18	WGHT 60	"W" Veneer Top Veneer Chassis CRP3030TC472W	1034	"G" High Pressure Laminate Top Veneer Chassis CRP3030TC472G	1034	"M" Thermally Fused Laminate Top Thermally Fused Laminate Chassis "M" Option N/A

2 SELECT A FINISH

"W" Veneer	"G" HPL	"M" TFL	
WAC	GAC	-	Amber Cherry
WRC	-	-	Caramel Cherry
WIC	GIC	-	Crimson Cherry
WEC	-	-	Ebony
WHC	GHC	-	Honey Cherry
WOC	GOC	-	KoKo Cherry
WSC	-	-	Scotch Cherry
WCM	GCM	-	Clear Maple
WWM	GWM	-	Wheat Maple
WEW	GEW	-	Executive Walnut
WGW	-	-	Gunstock Walnut
WBW	-	-	Henna Walnut
WJW	-	-	Judicial Walnut
WNW	GNW	-	Natural Walnut

3 SELECT AN EDGE



5 OPTIONS

- SOLID SURFACE TOP (FLAT EDGE ONLY)**
- Solid Surface: Black Pearl G10, Sea Oat Quartz G38, White Quartz G4
 - S53030: For corner size 30 x 30 - \$750

4 SELECT HARDWARE

Hardware
Option Not
Available

COMPUTER SUPPORT

DELUXE SINGLE MONITOR ARM W/ USB POST



STYLE NUMBER
MA1952

LIST PRICE
495

SPECIFICATIONS

- (4) 2.0 USB Ports
- Post Length: 22-1/2"H, Post Base Requires 80mm Dia. Hole
- Spring Assist - Full Movement Arm, Arm Extends Up To 13 - 3/8"
- Supports Screens Up To 24", Swivels 180 degrees - Mount Plate Tilts 85 degrees
- Arm: Die Cast Aluminum

Notes

- Surface Factory Bored / Ready To Install

COMPUTER SUPPORT

DELUXE DOUBLE MONITOR ARM W/ USB POST



STYLE NUMBER
MA2952

LIST PRICE
795

SPECIFICATIONS

- (4) 2.0 USB Ports
- Post Length: 22-1/2"H, Post Base Requires 80mm Dia. Hole
- Spring Assist - Full Movement Arm, Arm Extends Up To 13 - 3/8"
- Supports Screens Up To 24", Swivels 180 degrees - Mount Plate Tilts 85 degrees
- Arm: Die Cast Aluminum

Notes

- Surface Factory Bored / Ready To Install
- Can Accommodate Up To 4 Monitors By Ordering Extra Double Arms.
- 1 Extra Arm and 1 Double Clamp - Add\$305

COMPUTER SUPPORT

CPU RETRACTABLE CRADLE

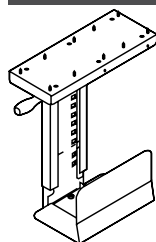

STYLE NUMBER
K18

LIST PRICE
195

SPECIFICATIONS

- Black Metal CPU Carriage
- Full 360° swivel capability allows easy access to rear of CPU for cables / wires
- Track allows 8- 1/2" extension
- Width Adjustment 5-1/2" to 9-1/4"
- Height adjustment 14- 5/8" to 20- 1/2"
- Black epoxy finish

Notes

- Factory Installed

COMPUTER SUPPORT

ARTICULATING KEYBOARD TRAY

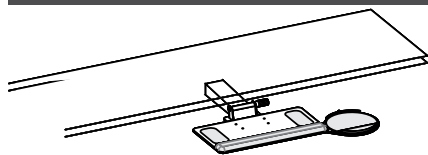

STYLE NUMBER
Factory Installed
K28
Field Installed
K28F

LIST PRICE
375
395

SPECIFICATIONS

- Adjusts effortlessly - A simple one-handed motion allows the keyboard to be repositioned instantly, without the use of locks or levers
- Encourages low-risk postures - Maximizes adjustability within a safe operating range.
- Will last a lifetime - Exceeds all applicable BIFMA Standards and comes with a lifetime guarantee.

Notes

- Available on: Freestanding Desk
- Factory Installed (standard)
- FIELD INSTALL - \$395

DOOR MODIFICATIONS

SOFT CLOSE DOOR HINGE



STYLE NUMBER
D9SC

LIST PRICE
15 Per Door

SPECIFICATIONS

- Snap onto standard door hinge
- Requires (2) per door
- Max door height 43"
- Factory installed where specified
- Individually shipped for field installation

Notes

- Specify Each Item To Have Slow Close Feature

DOOR MODIFICATIONS

DELETE DOORS

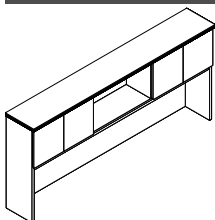

STYLE NUMBER
D6

LIST PRICE
N/C

SPECIFICATIONS

- Standard Door cabinets can have door deleted for open access. Modification of hinge rails and structural components are made face ready.

DRAWER OPTIONS

BOX DRAWER ACCESSORIES

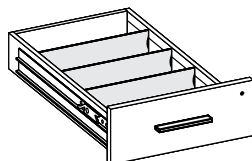

STYLE NUMBER
Wood Drawer Dividers w/ Clips
K-DIV
Single Tray - Utility Tray
K-Sut

LIST PRICE
SET OF 3 - 30

30 each

SPECIFICATIONS

- K-DIV Extra Wood Drawer Dividers with Clips, Top Box drawers standard with 1 divider
- K-SUT Single Tray - Utility Tray, Specify Legal or Letter drawer width

DRAWER OPTIONS - BOTTOM COVER

FELT BOTTOM CENTER DRAWER INSERT LINER

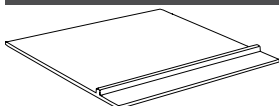

STYLE NUMBER
K3

LIST PRICE
95

SPECIFICATIONS

- Inserts into center drawer and features divider for open pen and pencil storage. Removable for easy cleaning.
- Adds a luxurious touch to center drawers.
- Color: Dark Brown Coal

LT-LED TASK LIGHT

LIGHTING

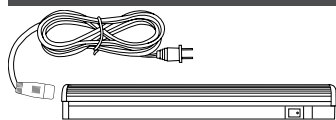

STYLE NUMBER	LIST PRICE	SPECIFICATIONS
24" Tasklight LT-LED24	90	- Anodized aluminum finish - Tilting beam allows adjustability - Switch with dimming control
48" Tasklight LT-LED48	165	- 50,000 hour life - 12V power drive standard with each task light 30 watt max
60" Tasklight LT-LED60	180	
Linking Cable LC24	20	Notes - LC24: 24" LT-LED Task light linking cable

PEDESTAL MODIFICATIONS

MODIFY DRAWER CONFIGURATIONS

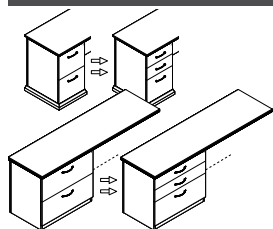

STYLE NUMBER	LIST PRICE	SPECIFICATIONS
File/File to Box/Box/File P6	50 per pedestal	- Modify File/File To Box/Box/File - Any Unit
Box/Box/File to File/File P6	50 per pedestal	
Lateral File to 2 Box Drawers P8	95 per pedestal	

POWER / DATA

POWER SUPPLY CORDESET



STYLE NUMBER	LIST PRICE	SPECIFICATIONS
PD717	95	- SIZE: 10.75" L x 2.0" W x 1.06" H - (5) Outlets w/ 10' cord - Surge suppression (720 Joules) - 15 Amp breaker - Available on: Vertical Panels, Cabinet Interiors, and under tops

PRODUCT MODIFICATIONS

MODIFY WIDTH - OPEN KNEESPACE

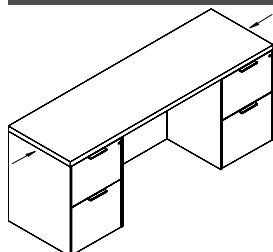

STYLE NUMBER	LIST PRICE	SPECIFICATIONS
MOD-1	125	- Modify width down on any unit with an open knee space: desk, workstation credenza, bridge, return

PRODUCT MODIFICATIONS **MODIFY WIDTH - OPEN/CLOSED STORAGE**

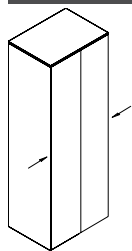

STYLE NUMBER
MOD-2

LIST PRICE
250

SPECIFICATIONS
- Modify width down on any unit with open or closed storage section: overheads, wall hung units, storage credenzas, towers

PRODUCT MODIFICATIONS **MODIFY WIDTH - OUTSIDE OF MOD-1, MOD-2**

STYLE NUMBER
MOD-3

LIST PRICE
Contact Factory for Pricing

SPECIFICATIONS
- Width modification outside of MOD-1 & MOD-2

PRODUCT MODIFICATIONS **MODIFY DEPTH - DECREASE DEPTH**

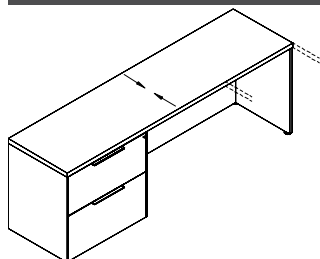

STYLE NUMBER
MOD-5

LIST PRICE
125

SPECIFICATIONS
- Modify depth down (minimum depth for a unit with drawers is 21"D)

Notes
- Ex. 24" to 21", 30" to 24", and 36" to 30"

PRODUCT MODIFICATIONS **MODIFY DEPTH - INCREASE DEPTH**

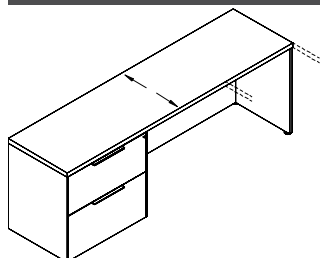

STYLE NUMBER
MOD-6

LIST PRICE
Add 10%

SPECIFICATIONS
- Increase depth

Notes
- Ex. 24" to 30", 30" to 36", and 36" to 42"

PRODUCT MODIFICATIONS

MODIFY HEIGHT

STYLE NUMBER
MOD-7

LIST PRICE
Contact Factory
for Pricing

SPECIFICATIONS
- Modify height of a unit

SPECIALTY VENEER ACCENTS

RECTANGLE INLAY - RECESSES DURA-LEATHER WRITING SURFACE



RECTANGLE INLAY

STYLE NUMBER
RL-29A

LIST PRICE
895

SPECIFICATIONS
- Recessed inlay desk pads are covered with Alomost Leather from Paul Brayton Designs.
- DARRAN will gladly custom quote other inlay materials ie: solid surfaces, biocomposites, metallic laminates, or genuine leather to match seating

WIRE MANAGEMENT

HORIZONTAL J-CHANNEL WIRE MANAGEMENT RACEWAY

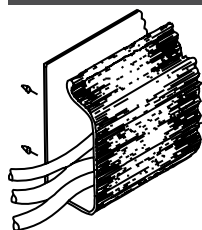

STYLE NUMBER
W1

LIST PRICE
75 Per 4 Foot
Section

SPECIFICATIONS
- 4' section for field installation.
- The "J" shape black thermoplastic wire raceway may be added to specified worksurface tops to provide concealed channeling of wires to and from worksurface grommets. For use in open kneespace areas, raceway is attachable to top of back panel with pan head screws. Interior dimensions are 1" x 1- 1/2" providing ample storage for multiple wires and excess cable. Front of raceway flexes out for easy cord insertion.

Notes
- Units w/ Wire Channel Standard.
- Field Installation

WIRE MANAGEMENT

HORIZONTAL WIRE MANAGEMENT RACEWAY

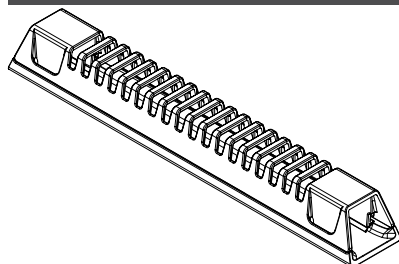

STYLE NUMBER
W21

LIST PRICE
30

SPECIFICATIONS
- 10"W x 1.5"D x 1.25"H
- Grey Wire Manager (10.5")
- Power and data cables can be discretely housed and managed with the W21 Gray Wire Manager. This can be mounted in any location to metal frame or underside of conference tables and runs cables through a 1" channel from power module to hollow steel legs. This keeps cables organized under the table top. Release clips make it simple to snap on and off the Wire Manager for easy organization and access after attached to the table

Notes
- Field installed

WIRE MANAGEMENT

HORIZONTAL U-CHANNEL WIRE MANAGEMENT RACEWAY



STYLE NUMBER
W2A

LIST PRICE
75 Per 4 Foot Section

SPECIFICATIONS
- 4' section for field installation.

Notes
- Units w/ Wire Channel Standard.
- Field Installation

WIRE MANAGEMENT

COIL WIRE MANAGER



STYLE NUMBER
W18

LIST PRICE
150

SPECIFICATIONS
- Weighted Base, Table attachment plate
- 39- 1/2" Length
- Black

Notes
- Location

WIRE MANAGEMENT

STANDARD LOCATION GROMMETS - FACTORY INSTALLED

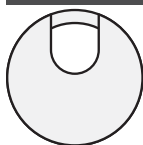

STYLE NUMBER
Standard Location Grommet
Black
TM30
Silver
TM31
Antique Brass
TM33
White
TM34

LIST PRICE
45
45
45
45
45

SPECIFICATIONS
- 1 -5/8" Metal Grommet

Notes
- *Units w/ Grommets Standard Are Noted Under Standard Features. Grommets Match Pull Finish - Standard (Unless Specified Otherwise)

WIRE MANAGEMENT

NON-STANDARD LOCATION GROMMETS - FACTORY INSTALLED

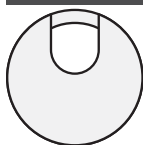

STYLE NUMBER
Non-Standard Location Grommet
Black
TM30 -NS
Silver
TM31 -NS
Antique Brass
TM33 -NS
White
TM34 -NS

LIST PRICE
90
90
90
90
90

SPECIFICATIONS
- 1 -5/8" Metal Grommet

Notes
- *Units w/ Grommets Standard Are Noted Under Standard Features. Grommets Match Pull Finish - Standard (Unless Specified Otherwise)

WIRE MANAGEMENT

BLACK PLASTIC VERTICAL SURFACE GROMMETS - FACTORY INSTALLED



STYLE NUMBER	LIST PRICE	SPECIFICATIONS
<i>Standard Location Grommet</i>		- 2 " Black Plastic Grommet
TM50-C	45	
<i>Non-Standard Location Grommet</i>		Notes - Standard Location is Bottom Center
TM50-NS	90	

AIRCHARGE WIRELESS CHARGING GROMMET

STYLE NUMBER

LIST PRICE



ACWG WIRELESS GROMMET

\$195



SPECIFICATIONS

- When used with GROVE Tables an additional \$350 LIST will apply for the special cutout required.
- AirCharge offers a convenient way to charge any Qi compatible smartphone or device without the need to carry charging cables or find an available power outlet.
- The Aircharge is powered by the latest Qi compliant IC offering reliable and efficient wireless charging in a convenient 3" grommet hub. Simply place your phone on the Aircharge and an LED will confirm pairing and begin wireless charging.
- Recess: Efficient space conservation and quick access
- Input: DC 5V (with included AC power adapter), DC 9V, 1.67A (with optional QC 2.0 power adapter)
- Output: 5 watts Max. with DC 5V, 2A power adapter, 10 watts Max. with QC 2.0 power adapter
- Qi V1.2 compliant IC
- Charging distance: 6mm Max.

AirCharge Wireless Grommet



AVAILABLE

- All Darran Collections

COVE POWER UNIT - NON-LINKING

STYLE NUMBER

LIST PRICE



PD COVE PLUG
Non-Linking Version

\$550

SPECIFICATIONS

- Size 5.75" L x 2.5" W
- When used with GROVE Tables an additional \$350 LIST will apply for the special cutout required.
- (2) 15 Amp Receptacles and (2) USB charging ports
- Surface Mount
- 108" Cord
- Standard Silver Finish, Available in White or Black Finish upon request
- ETL Listed

AVAILABLE

- All Darran Collections



COVE CORDED SERIES

STYLE NUMBER

LIST PRICE



PD-COVE-PKO

\$800



SPECIFICATIONS

- Size 9.5" L x 2.5" W x 3.18" D
- When used with GROVE Tables an additional \$350 LIST will apply for the special cutout required.
- (2) Power Receptacles, (2) 2.1 Amp USB charging ports and (1) Telecom Plate Knockout
- Surface Mount
- 108" Cord
- Standard Silver Finish, Available in White or Black Finish upon request
- ETL Listed

AVAILABLE

- All Darran Collections

TELECOM PLATES

THIS POD CAN HAVE UP TO 1 TOTAL PLATES

STYLE NUMBER	LIST PRICE
RJ45 (1)	\$35
RJ45 (2)	\$70
RJ45 (3)	\$105
USB (1)	\$70
USB (2)	\$140
RJ11/RJ45	\$70
RJ45/USB	\$105
RJ45/HDMI	\$190
HDMI/DVI	\$325
HDMI/USB	\$205
HDMI/VGA	\$240
VGA/MINI-STEREO	\$155
VGA/USB	\$175

SOBA WIRE MANAGER

STYLE NUMBER	LIST PRICE
<i>STARTER UNITS</i>	
SCDW White wire manager	\$200
SCDB Black wire manager	\$200



SPECIFICATIONS

- Dimensions: 9ft x 9in x 3.15in
- Zips up, bundles and routes loose, messy cables into a single tube
- Routes and guides cables behind desks, TVs, and anywhere cables tend to get messy
- Accommodates large or small cables, up to three cables at once

AVAILABLE

- All collections (excludes Spire, Occasional and Seating)



VILLA POWER UNIT - NON-LINKING

STYLE NUMBER

LIST PRICE



VIL-C PLUG
Non-Linking

\$515

SPECIFICATIONS

- Size: Top Grommet 5.68"L X 3.39"W; Under Top 12"L x 3.13"W x 3.08"D
- (2) Power receptacles; (2) USB charging ports and (1) Knockouts for RJ45 Data Ports
- Surface Mount
- 72" Cord (Longer cord available, contact Customer Service)
- Standard Silver Finish, Black Finish available upon request
- UL or ETL Certified

AVAILABLE

- All Darran Collections
- Excludes Grove

RJ45 KNOCKOUT

STYLE NUMBER

LIST PRICE

RJ45 (1)

\$35

